

# Product Catalog

## Measurement Microphones

Q1 2026



# We Make Microphones

GRAS is a worldwide leader in the sound and vibration industry. We develop and manufacture state-of-the-art measurement microphones and related equipment for industries where acoustic measuring accuracy and repeatability is of the utmost importance. This includes applications and solutions for customers within the fields of aerospace, automotive, audiology, consumer electronics, and other highly demanding industries.

## Innovation

As a company dedicated to innovation, we safeguard our heritage by constantly striving to push the boundaries of what is possible and help our customers improve their products. This is why we have the industry's most advanced microphones—a broad range of high-quality microphones for general acoustic applications complemented by an even broader range of highly specialized microphones and test solutions developed and fine-tuned to match specific challenges.

This is a reflection of our unique willingness to help solve our customers' measurement needs and provide solutions for tomorrow. Listening to our customers is at the core of who we are.

## Quality

Our measurement microphones are designed to support critical areas in our customers' R&D, QA and Production Line testing. Using Highly Accelerated Lifetime Tests (HALT) we ensure that our microphones perform optimally in real-life situations and retain the long-term stability that is crucial for trustworthy measurement results. All our microphones are made in Denmark and crafted to a quality standard that allows us to offer a 5-year warranty on most models.

## Repair Service

Most GRAS microphones are manufactured in a way that makes it possible for them to be repaired from certain types of damage. So should you by mistake damage a GRAS microphone, repairing service at a reasonable price is available, ensuring a very low cost of ownership.

## Calibration Services

Depending on the use, measurement environment and internal quality control programs, we recommend that microphones are calibrated at a dedicated calibration laboratory at least every second year. We endorse our Accredited Calibration Laboratory in Denmark or the GRAS Microphone Calibration Centers located in Asia, Europe and North America.

## Partners

GRAS Sound & Vibration is represented through subsidiaries and distributors in more than 40 countries and is part of Axiometrix Solutions, a leading test solutions provider comprised of globally recognized measurement brands.

Please visit [grasacoustics.com](http://grasacoustics.com) to find your local GRAS partner.



## Tradition

We were founded in 1994 by Danish acoustics pioneer Gunnar Rasmussen who for more than 60 years has contributed to the world of sound and vibration with his unique ideas and designs. In 1956 Mr. Rasmussen designed the first reproducible 1" condenser measurement microphone. Mr. Rasmussen's ingenuity soon led to the world's most popular and probably most copied acoustic sensor: The 1/2" measurement microphone. Then the 1/4" and 1/8" microphones followed with outstanding dynamic and high-frequency capabilities that made high-definition diagnostics of impulse noise possible. Many variants have been made available over the years, all based on Gunnar Rasmussen's original 1" pressure microphone design.



<b>Microphone Selection</b>	<b>6</b>
Selecting a Measurement Microphone.....	6
Externally Polarized vs Prepolarizedq.....	7
Traditional/LEMO vs CCP preamplifiers .....	7
Free, Pressure, Diffuse or Multi Field .....	8
Dynamic Range of a Microphone .....	10
Frequency Range of a Microphone .....	11
<b>Microphone Sets and Microphones</b>	<b>12</b>
CCP Microphone Sets .....	14
LEMO Microphone Sets .....	18
Prepolarized Measurement Microphone .....	20
Externally Polarized Measurement Microphones.....	22
Externally & Prepolarized Intensity Microphones .....	24
<b>Production Line Microphones</b>	<b>25</b>
Production Line Microphones.....	26
EQset Technology:.....	28
<b>Special Microphones</b>	<b>30</b>
Surface Microphones .....	32
Flush-mount Microphone Sets .....	34
Probe Microphones .....	36
Low-frequency Microphone Sets .....	37
Array Microphones & Ground Array Kits.....	38
Hemispheres .....	39
<b>Preamplifiers</b>	<b>40</b>
1/2" Traditional Lemo Preamplifiers .....	42
1/4" Traditional Lemo Preamplifiers .....	43
1/2" CCP Preamplifiers.....	44
1/4" CCP preamplifiers.....	45
<b>Microphones for Outdoor Use</b>	<b>46</b>
Outdoor Microphones .....	48
<b>Low-noise Measuring Systems</b>	<b>50</b>
Low-noise Measuring Systems .....	52
<b>Intensity Probes</b>	<b>54</b>
Intensity Probes .....	56

<b>Calibration Equipment</b>	<b>60</b>
Calibration Equipment .....	62
Calibration Systems .....	66
<b>Artificial Ears, Ear and Mouth Simulators, and KEMAR</b>	<b>68</b>
Ear Simulator Kits .....	70
Couplers and Ear Simulators .....	74
ITU-T Pinna Simulators .....	75
IEC 60318-4 Ear Simulators .....	76
Evolution of the IEC 60318-4 (711).....	77
KEMAR .....	78
Acoustic Test Fixtures .....	80
Headphone Test Fixture .....	84
Mouth Simulators .....	86
AutoArray.....	87
The Gold Standard in In-Cabin Acoustic Testing.....	87
Acoustic Test Chamber .....	88
<b>Power Modules</b>	<b>90</b>
Power Modules .....	91
Power Modules for Low-noise Systems .....	98
<b>Accessories</b>	<b>99</b>
Accessories Microphones and Preamplifiers.....	100
Microphone Protection Grids.....	103
Accessories for Microphones—Mounting.....	105
Accessories for Microphones—Miscellaneous .....	108
Accessories for Outdoor Microphones.....	109
Accessories for Artificial Ears & Mouths.....	111
Pinnae for KEMAR, 45CA and 45CB.....	114
Accessories for Pistonphones and Sound Calibrators.....	115
Accessories for Array Modules .....	117
Accessories for Power Modules.....	118
Cables.....	119
Cable Accessories .....	122
Windscreens.....	123
<b>Index</b>	<b>124</b>

## Selecting a Measurement Microphone

Measurement microphones are available in many types covering different frequency and dynamic ranges, form factors, mounting methods and applications. The following guide is provided to help select the right microphone for a given application.

The first steps for selecting a microphone involves a number of choices, which can be summarized as:

- ✓ Microphone capsule technology: Externally polarized vs prepolarized.
- ✓ Preamplifier technology: Traditional LEMO vs CCP.
- ✓ Sound field optimization: Free, Pressure, Diffuse or Multi field.
- ✓ Dynamic range.
- ✓ Frequency range.



## Externally Polarized vs Prepolarized

All GRAS measurement microphones are of the condenser type. This requires a polarization voltage, which can either be supplied from an external power supply or the microphone itself can be polarized by injecting a permanent electrical charge into a thin layer of material placed on top of the microphone's backplate.

### Externally Polarized Microphones

These microphones require external equipment to supply the polarization voltage for the microphone capsule, typically 200 V. Externally polarized microphones were the first technology used in modern measurement microphones. Although they have gradually lost popularity to prepolarized types, they remain the preferred choice for highly demanding measurements where maximum accuracy and long-term stability are essential.

GRAS examples: 40AF, 40BP and 40DP.

### Prepolarized Microphones

These microphones use an electrically charged layer mounted directly on the backplate, which provides the necessary polarization voltage internally—hence the term prepolarized. As a result, they do not require external equipment for polarization, simplifying the design of the associated preamplifier electronics as well as the cables, connectors, and analyzers used with these microphone capsules. Because of these advantages, prepolarized microphones have become the most widely adopted option for measurement applications.

GRAS examples: 40AE, 40BD and 40DD.

---

## Traditional/LEMO vs CCP preamplifiers

Just as with microphone capsules, there are also two main types of preamplifiers that are used together with measurement microphones. The difference between these two types lies in the type of power supply needed to drive the internal circuitry of the preamplifier. Unlike microphone capsules, where prepolarized capsules do not need an external supply to work, preamplifiers will always require an external supply. It is possible to classify preamplifiers into two main types.

### Traditional/LEMO preamplifiers

These are referred to as traditional preamplifiers since it was the first technology used for measurement microphones. They are voltage driven, using both single-sided and/or dual-sided power supplies (some preamplifiers will support both types of supplies, like  $\pm 15$  V,  $\pm 60$  V, +28 V and +120 V). They are also referred to as “LEMO” type, given the fact that they are typically equipped with multi-pin LEMO-style connectors for multi-wire cables. This multi-pin connector will carry the signal out of the microphone, the preamplifier supply, microphone capsule polarization voltage, etc., in different wires separately. Traditional preamplifiers typically use variations of multi-pin LEMO-type connectors such as 4-, 5-, and 7-pin and multi-wire cables. It is important to note that traditional preamplifiers can be used with both externally polarized and prepolarized microphone capsules.

GRAS examples: 26AA, 26AB, 26AC-1, 26AK and 26AS.

### CCP preamplifiers\*

Also known as integrated electronic piezoelectric (IEPE), integrated circuit piezoelectric (ICP<sup>®</sup>) and constant current line drive (CCLD). Compatible with many other constant-current driven products such as Deltatron<sup>®</sup>, Isotron<sup>®</sup>, etc. The CCP principle is a two-wire system using one wire for both the constant-current supply for the preamplifier and the signal output. The signal is superimposed on the wire through which the current is kept constant. The other wire is used for ground connection. A CCP preamplifier uses a constant-current power supply, which must be between 2 and 20 mA (typically 4 mA), to produce a constant nominal voltage level of typically 8-14 V DC (referred to as the bias voltage) to drive the preamplifier. The output signal from the microphone superimposes fluctuations around the DC level. CCP preamplifiers typically use BNC, Microdot 10/32 and SMB connectors with coaxial cables, and can only be used with prepolarized microphone capsules.

GRAS examples: 26CA, 26CB, 26CC, 26CF and 26CK.

\* CCP is the same as Integrated Electronics Piezo-Electric (IEPE) and Constant Current Line Drive (CCLD) and is compatible with many other constant current driven products such as Deltatron<sup>®</sup> (Brüel & Kjaer), Isotron<sup>®</sup> (Endevco Corp.), ICP<sup>®</sup> (PCB Group, Inc.).

## Free, Pressure, Diffuse or Multi Field

Measurement microphones can be divided into three groups: Free Field, Pressure, and Random Incidence. The differences between microphones from group to group are at the higher frequencies, where the size of a microphone becomes comparable with the wavelengths of the sound being measured. GRAS also offers a fourth category of measurement microphone called Mutifield, that can be used in any of the previously mentioned sound fields.

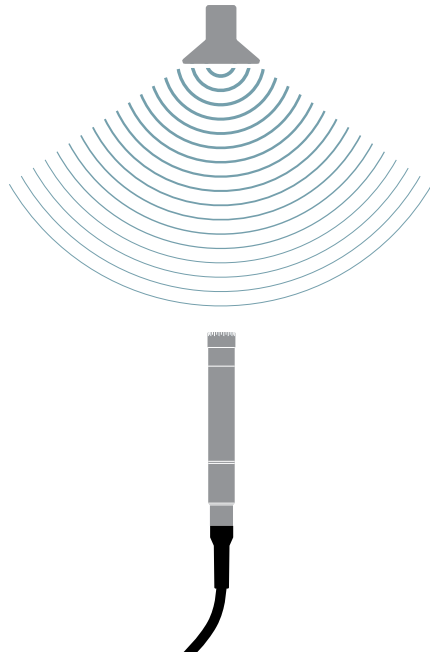

### Free-field Microphones

A free-field microphone is designed essentially to measure the sound pressure as it was before the microphone was introduced into the sound field. At higher frequencies, the presence of the microphone itself in the sound field will disturb the sound pressure locally. The frequency response of a free-field microphone has been carefully adjusted to compensate for the disturbances to the local sound field.

Free-field microphones are the most common type of microphone used for acoustic measurements. They are best suited for laboratory measurements, such as acoustic tests inside anechoic chambers, sound power measurements or sound radiation studies. But can also be found in the field used with sound level meters.

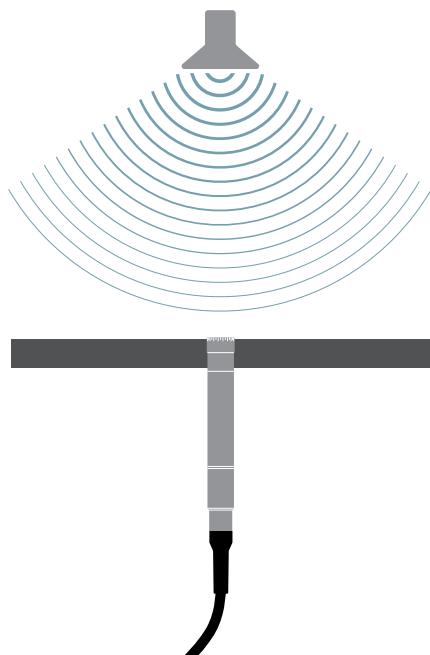

### Pressure Microphones

A pressure microphone is for measuring the actual sound pressure on the surface of the microphone's diaphragm. A typical application is in the measurement of sound pressure in a closed coupler or, as shown to the left, the measurement of sound pressure at a boundary or wall; in which case the microphone forms part of the wall and measures the sound pressure on the wall itself.

Pressure microphones are commonly used with ear simulators, such as the IEC 60318-4 '711 coupler' (GRAS RA0045). They are also flush-mounted to surfaces like wind tunnel walls, positioned inside small cavities—such as those found in car engines—or placed very close to sound sources, like during loudspeaker testing in production line environments.

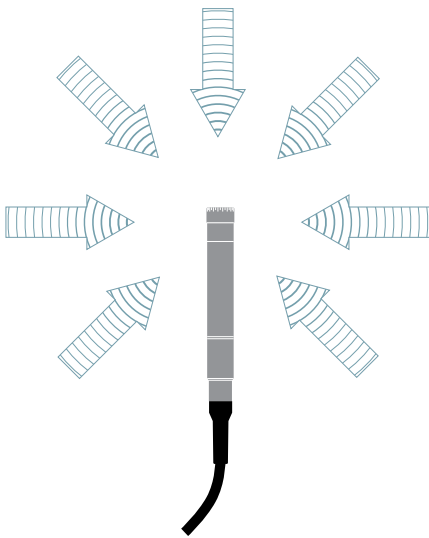

### Diffuse-field Microphones

Also called random-incidence microphones. They are used for measuring sound fields, where the sound comes from many directions e.g. when measuring in a reverberation chamber or in other highly reflecting surroundings.

The combined influence of sound waves coming from all directions depends on how these sound waves are distributed over the various directions. For measurement microphones, a standard distribution has been defined based on statistical considerations; resulting in a standardized random-incidence microphone.

Diffuse-field microphones are commonly used in highly reverberant environments, such as reverberation chambers, or any space that approximates a diffuse sound field. Additionally, many ANSI standardized acoustic tests specify the use of diffuse-field microphones.

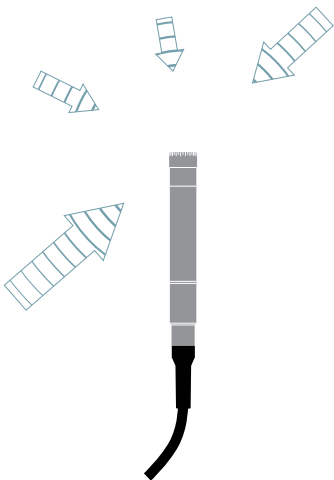

### Multi-field Microphones

GRAS also offers Multifield (MF) microphones. These microphones are designed for use in any ideal sound field—such as free, pressure, or diffuse fields—as their calibration chart includes frequency response data for each of these conditions.

However, MF microphones excel in non-ideal sound fields, such as environments that fall between free and diffuse fields. In such conditions, they exert less influence on test results compared to other types of microphones.

## Dynamic Range of a Microphone

The dynamic range of a microphone can be defined as the range between the lowest level and the highest level that the microphone can handle. This is not only a function of the microphone alone but also of the preamplifier used with the microphone. The dynamic range of a microphone is, to a large extent, directly linked to its sensitivity.

In general, a microphone with high sensitivity will be able to measure very low levels, but not very high levels, and a microphone with low sensitivity will be able to measure very high levels, but not very low levels.

The sensitivity of a microphone is determined chiefly by the size of the microphone and the tension of its diaphragm. Generally speaking, a large microphone, with a loose diaphragm, will have high sensitivity and a small microphone, with a stiff diaphragm, will have low sensitivity.

### Upper Limit of Dynamic Range

The highest levels that can be measured are limited by the amount of movement allowed for the diaphragm before it comes into contact with the microphone's backplate.

As the level of the sound pressure on a microphone increases, the deflection of the diaphragm will accordingly be greater and greater until, at some point, the diaphragm strikes the backplate inside the body of the microphone. This is ultimately the highest level the microphone can measure.

When connected to the preamplifier, the upper dynamic range can be limited by the maximum signal voltage swing allowed by the preamp. This preamplifier voltage swing will be determined by the preamplifier technology used (e.g. Traditional LEMO or CCP) and the preamplifier's power supply.

### Lower Limit of Dynamic Range

It is also known as the microphone's noise floor. The thermal agitation of air molecules is sufficient for a microphone to generate a very small output signal, even in absolutely quiet conditions. This "thermal noise" lies normally at around 5  $\mu$ V and will be superimposed on any acoustically excited signal detected by the microphone. Because of this, no acoustically excited signal below the level of the thermal noise can be measured.

The dynamic ranges of various GRAS microphones are shown in the chart below. Different colors are used to distinguish between pressure (blue), free-field (orange) and random-incidence (light grey) microphones.

When connected to the preamplifier, the lower limit of dynamic range can also be affected by the electrical noise of the preamplifier circuit itself.

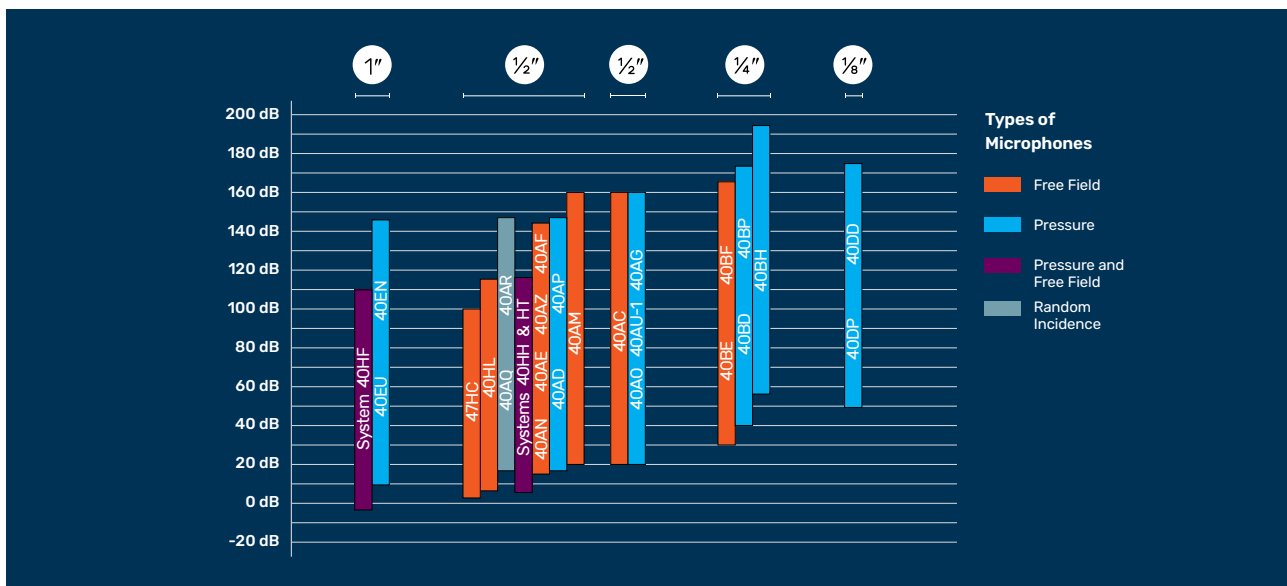

The microphones are grouped according to size of external diameter, i.e., 1", 1/2", 1/4" and 1/8". The Part or Model number of each microphone is also shown.

## Frequency Range of a Microphone

The frequency range of a microphone is defined as the interval between its upper limiting frequency and its lower limiting frequency. With today's microphones, it is possible to cover a frequency range starting from around 1 Hz and reaching up to 140 kHz.

Low-frequency measurements require a microphone with a well-controlled static pressure equalization with a very slow venting. Special versions are available for infra-sound measurements.

High-frequency measurements are very sensitive to diaphragm stiffness, damping and mass as well as diffraction.

### Upper Limiting Frequency

The upper limiting frequency is linked to the size of the microphone, or more precisely, the size of the microphone compared with the wavelength of sound. Since wavelength is inversely proportional to frequency, it gets progressively shorter at higher frequencies. Hence, the smaller the diameter of the microphone, the higher are the frequencies it can measure. On the other hand, the sensitivity of a microphone is also related to its size which also affects its dynamic range.

The frequency ranges of various GRAS microphones are shown in the chart below. Different colors are used to distinguish between pressure (blue), free-field (orange) and random-incidence (light grey) microphones.

### Lower Limiting Frequency

The acoustical cut-off or acoustical lower limiting frequency of a microphone is determined by its static pressure equalization system. Basically, a microphone

measures the difference between its internal pressure and the ambient pressure.

If the microphone was completely airtight, changes in barometric pressure and altitude would result in a static deflection of its diaphragm and, consequently, in a change of frequency response and sensitivity.

To avoid this, the microphone is manufactured with a static pressure equalization channel for equalizing the internal pressure with ambient pressure. On the other hand, equalization must be slow enough to avoid affecting the measurement of dynamic signals.

When connected to the preamplifier, the input impedance of the preamplifier together with the capacitance of the microphone capsule will determine the electrical lower limiting frequency. By controlling the acoustical and electrical cut-off frequency of the microphone and preamplifier combination, its lower limiting frequency can be defined.

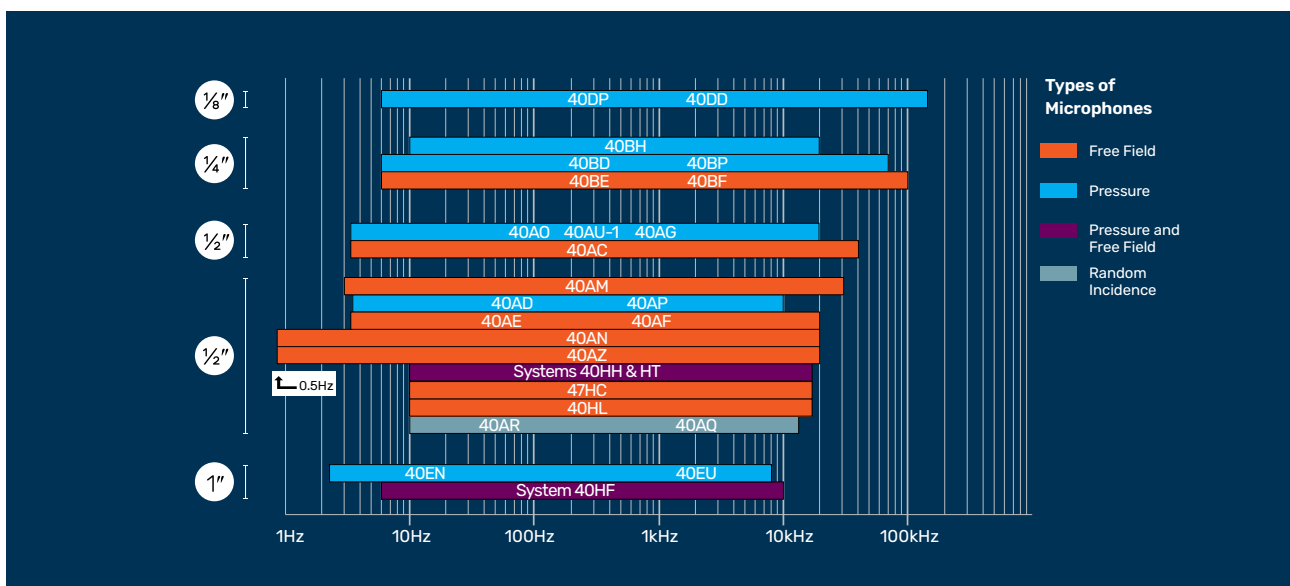

The microphones are grouped according to size of external diameter, i.e., 1", 1/2", 1/4" and 1/8".

The Part or Model number of each microphone is also shown.

# Microphone Sets and Microphones

## Microphone Sets—a Safe and Easy Solution

Daily situations where you mix up externally polarized and prepolarized microphones and preamplifiers or use wrong calibration data in your system setup are time-consuming and often not discovered until a whole set of measurement data is analyzed and consequently discarded.

To help you avoid this we offer most of our measurement microphones as microphone sets: Pre-assembled and ready-to-use combinations of microphones and preamplifiers.

## Pre-assembled Sets

The GRAS 46XX-series of pre-assembled microphones and preamplifiers offers carefully selected combinations to obtain the best possible properties and reliability, thus optimizing the work-flow for the user and minimizing typical handling errors.

The sets are assembled in a dust-free environment to avoid contamination of the interface between the microphone and preamplifier. They are calibrated together and sealed with a label. The label can be removed and the set dismantled if desired by the user.

## Easy Selection

The measurement microphone sets have been combined so they fulfill our users' typical measurement needs. Whatever your measurement system and application, you should be able to find a set that suits your needs.

## Plug & Play

The microphone sets can be connected directly to all professional measurement systems, and as indicated they are available for both CCP and 7-pin LEMO inputs. If your measurement platform supports intelligent transducers according to IEEE 1451.4 Transducer Electronic Data Sheet (TEDS) you can simply plug in the microphones and they will identify themselves with their specific properties, types and calibration data. This feature is especially appreciated by multi-channel users.

## Cables

The CCP sets use high-quality coaxial cables whereas the LEMO sets use a special, soft type of multi-core shielded cable. It should be noted that longer cables will influence the upper limiting frequency and dynamic ranges.

## Calibration Data

All microphone sets are delivered as a unit and are calibrated accordingly. The sets are delivered with calibration charts including sensitivity values and frequency response curves for the complete set. The sensitivity value can therefore be used directly in your system setup.

## Verification and Annual Calibration

For frequent verification of the measurement chain, a sound source will be required. GRAS supplies a number of pistonphones and a multifunction sound calibrator for this purpose. Depending on the use and your internal quality control requirements we recommend that the sets are recalibrated at least every second year.

## Warranty

GRAS offers a 5-year warranty on most microphone sets.

## Service

Should you by mistake damage a GRAS microphone, repairing service at a reasonable price is available, ensuring a very low cost of ownership. Cable and connector can usually be replaced, which is also the case for the microphone cartridge and preamplifier unit.

Typically a GRAS microphone set is named for the microphone capsule. A 40AE microphone thus becomes a 46AE microphone set when paired with the preamplifier.



# CCP MICROPHONE SETS

## FREE FIELD AND PRESSURE

### GRAS 246AE

#### 1/2" CCP Free-field SysCheck2™ Microphone Set



246AE is a 1/2" free-field general-purpose high-sensitivity microphone set with built-in TEDS, SysCheck2 functionality and BNC connector.

### GRAS 147AX

#### CCP Rugged Pressure Microphone



147AX is a surface mounted pressure microphone. It comes with a novel magnetic mounting system which provides precise, repeatable and easy mounting. It is well protected against vibrations, humidity, dust, oil mists, and temperatures from -40 to 125 °C. *Special windscreen for this microphone is available on page 123.*

### GRAS 146AE

#### 1/2" CCP Free-field Microphone Set



146AE is a versatile 1/2" free-field measurement microphone set for the broadest range of noise measurements in challenging environments. It is well protected against vibrations, humidity, dust, oil mists, and temperatures from -40 to 125 °C. *Special windscreen for this microphone is available on page 123.*

### GRAS 147EB

#### CCP X-Rugged Microphone Set



147EB is a rugged microphone set optimized for wheelhouse brake-noise measurements. It comes with a three-layer protection system that enables it to withstand the conditions in the wheelhouse during prolonged testing on public roads in all types of climate and weather. It is well protected against vibrations, humidity, dust, oil mists, and temperatures from -40 to 125°C.

### GRAS 46AE

#### 1/2" CCP Free-field Standard Microphone Set



46AE is a 1/2" free-field general-purpose high-sensitivity microphone set with built-in TEDS and BNC connector.

*Special windscreen for this microphone is available on page 123. Visit [www.grasacoustics.com](http://www.grasacoustics.com) for further accessories.*

	Nominal Sensitivity	Frequency Response	Power Supply	Dynamic Range	Max. Output Peak Voltage	Temperature Range	Length	Diameter without Protection Grid	Diameter with Protection Grid	Weight
246AE	50	3.15 – 20 k	2 – 20	17 dB(A) to 138 dB	8	-30 to +85	84	12.7	13.2	33
147AX	45	3.15 – 20 k	2 – 20	19 dB(A) to 133 dB	8	-40 to +125	-**	12.5	14.5	27
146AE	50	3.15 – 20 k	2 – 20	18 dB(A) to 133 dB	8	-40 to +125	86.5	12.7	14.5	35
147EB	50	3.15 – 20 k*	2 – 20	18 dB(A) to 133 dB	8	-40 to +125	87.2	12.7	23.77	61.5
46AE	50	3.15 – 20 k	2 – 20	17 dB(A) to 138 dB	8	-30 to +85	84	12.7	13.2	40
Units	mV/Pa	Hz	mA	re. 20 µPa	V	°C	mm	mm	mm	g

\* After correction for the influence of the 1" grid.

\*\* with 5 m integrated cable.

**GRAS 46AD**

**1/2" CCP Pressure Standard Microphone Set, High Sensitivity**



46AD is a 1/2" pressure high-sensitivity microphone set. Its high sensitivity gives it an unusual low noise floor for a 1/2" pressure microphone.

**46A0-S2**

**1/2" CCP Pressure Microphone Set, very short**



The 46A0-S2 is a 1/2" CCP pressure microphone set with a very short preamplifier made for confined spaces.

**GRAS 46AM**

**1/2" CCP Free-field Standard Microphone Set, Wide Frequency**



46AM is a 1/2" CCP microphone set with a wider frequency range compared to other 1/2" microphone. It can be used to measure signals up to 31.5 kHz.

**GRAS 46AQ**

**1/2" CCP Diffuse-field Standard Microphone Set**



46AQ is a 1/2" CCP high-sensitivity diffuse-field microphone set, optimized to measure sound correctly in random, diffuse and reverberant sound fields; with built-in TEDS and BNC connector.

**GRAS 46A0**

**1/2" CCP Pressure Standard Microphone Set**



46A0 is a 1/2" pressure high precision microphone set for laboratory work. Including built-in TEDS and BNC connector.

*A front-vented version is available, 46A0-FV.*

	Nominal Sensitivity	Frequency Response	Power Supply	Dynamic Range	Max. Output Peak Voltage	Temperature Range	Length	Diameter without Protection Grid	Diameter with Protection Grid	Weight
46AD	50	3.15 – 10 k	2 – 20	18 dB(A) to 138 dB	8	-30 to +85	94	12.7	13.2	40
46AM	14.5	3.15 – 31.5 k	2 – 20	25 dB(A) to 149 dB	8	-30 to +85	90	12.7	13.2	40
46A0	12	3.15 – 20 k	2 – 20	25 dB(A) to 150 dB	8	-30 to +85	80	12.7	13.2	39
46A0-S2	12	3.15 – 20 k	2 – 20	25 dB(A) to 150 dB	8	-30 to +85	42	12.7	13.2	25
46AQ	50	3.15 – 12.5 k	2 – 20	17 dB(A) to 138 dB	8	-30 to +85	101	12.7	13.2	40
Units	mV/Pa	Hz	mA	re. 20 µPa	V	°C	mm	mm	mm	g

# CCP MICROPHONE SETS

MULTIFIELD, FREE FIELD AND PRESSURE

## GRAS 46BC

1/4" CCP Multifield Microphone Set, High Sensitivity



46BC is a true multifield microphone for use in pressure, free-field, or random-incidence environments or any scenarios where the sound field is ill-defined or changing.

## GRAS 46BE

1/4" CCP Free-field Standard Microphone Set, Wide Frequency



46BE is a 1/4" Constant Current Power CCP free-field microphone set for measuring high sound pressure levels at high frequencies. It is terminated with a 10/32 UNC Microdot female connector and has TEDS. *A high-temperature version is available, 46BE-HT.*

## GRAS 46BD

1/4" CCP Pressure Standard Microphone Set



46BD is a 1/4" pressure microphone set with low sensitivity for high-level and high-frequency measurements, with built-in TEDS and Microdot connector. *A front-vented version is available, 46BD-FV. A version with SMB connector is available, 46BD-S1.*

## GRAS 46BG

1/4" CCP Pressure Standard Microphone Set, High Pressure



46BG is a 1/4" microphone set for high level measurement with built-in TEDS and a Microdot connector. Its low sensitivity and special-designed diaphragm make it ideal for handling high levels. *A front-vented version is available, 46BG-FV.*

	Nominal Sensitivity	Frequency Response	Power Supply	Dynamic Range	Max. Output Peak Voltage	Temperature Range	Length	Diameter without Protection Grid	Diameter with Protection Grid	Weight
46BC	20	4 – 20 k	3.5 – 10	24 dB(A) to 145 dB	8	-20 to +80	53	6.35	6.9	8
46BD	1.45	4 – 70 k	2 – 20	44 dB(A) to 166 dB	8	-30 to +85	53	6.35	6.9	10
46BE	3.6	4 – 80 k	2 – 20	35 dB(A) to 160 dB	8	-30 to +85	53	6.35	6.9	10
46BG	0.25	3.15 – 70 k	2 – 20	60 dB(A) to 184 dB	8	-30 to +85	53	6.35	6.9	8
Units	mV/Pa	Hz	mA	re. 20 µPa	V	°C	mm	mm	mm	g

**GRAS 46BL-1**

**1/4" CCP Pressure Microphone Set,  
High Sensitivity**



The 46BL-1 is a high-sensitivity 1/4" measurement microphone designed with an exceptionally low noise floor for a microphone of its size.

A front vented version is available as 46BL-1-FV.

**GRAS 46DE**

**1/8" CCP Pressure Standard Microphone Set**



46DE is a 1/8" CCP Pressure Microphone Set with Microdot connector. The preamplifier is 1/8", making it the world's smallest microphone set.

**GRAS 46DD**

**1/8" CCP Pressure Standard Microphone Set**



46DD is a low sensitivity microphone set for sound measurements at high frequencies. With built-in TEDS and Microdot connector.

A front-vented version is available, 46DD-FV.

	Nominal Sensitivity	Frequency Response	Power Supply	Dynamic Range	Max. Output Peak Voltage	Temperature Range	Length	Diameter without Protection Grid	Diameter with Protection Grid	Weight
46BL-1	20	4 – 20 k	3.5 – 10	24 dB(A) to 146 dB	8	-30 to +85	53	6.35	6.9	8
46DD	0.8	6.5 – 140 k*	2 – 20	52 dB(A) to 174 dB	8	-30 to +85	64	3.2	3.5	8
46DE	0.8	6.5 – 140 k*	2 – 20	52 dB(A) to 174 dB	8	-30 to +85	38.2	3.2	3.5	7
Units	mV/Pa	Hz	mA	re. 20 µPa	V	°C	mm	mm	mm	g

\* ±3 dB.

# LEMO MICROPHONE SETS

## FREE FIELD AND DIFFUSE FIELD

### GRAS 46AC

**1/2" LEMO Free-field Standard Microphone Set, Wide Frequency**



46AC is a high-performance 1/2" free-field standard microphone set for measuring medium sound pressure levels at high frequencies; with built-in TEDS and 7-pin LEMO connector.

### GRAS 46AR

**1/2" LEMO Diffuse-field Standard Microphone Set**



46AR is a 1/2" high-sensitivity Diffuse-field microphone set optimized to measure sound correctly in random, diffuse and reverberant sound fields; with built-in TEDS and 7-pin LEMO connector.

### GRAS 46AF

**1/2" LEMO Free-field Standard Microphone Set**



46AF is a 1/2" general-purpose high-sensitivity free-field microphone set with built-in TEDS and 7-pin LEMO connector.

### GRAS 46BF-1

**1/4" LEMO Free-field Standard Microphone Set**



46BF-1 is a 1/4" high frequency free-field microphone set for high level measurements with built-in TEDS and a 5-pin LEMO connector.

*To be used with AA0091 5-pin to 7-pin LEMO cable.*

	Nominal Sensitivity	Frequency Response	Power Supply	Dynamic Range	Temperature Range	Length	Diameter without Protection Grid	Diameter with Protection Grid	Weight
46AC	12.5	3.15 – 40 k	28 – 120	20 dB(A) to 164 dB	-30 to +70	97	12.7	13.2	42
46AF	50	3.15 – 20 k	28 – 120	17 dB(A) to 149 dB	-30 to +70	101	12.7	13.2	42
46AR	50	3.15 – 16 k*	28 – 120	19 dB(A) to 149 dB	-30 to +70	101	12.7	13.2	42
46BF-1	3.6	4 – 100 k	28 – 120	35 dB(A) to 172 dB	-30 to +70	69	6.35	6.9	10
Units	mV/Pa	Hz	V DC	re. 20 µPa	°C	mm	mm	mm	g

\* ±3 dB. All other ±2 dB.

**GRAS 46AG**

**1/2" LEMO Pressure Standard Microphone Set**



46AG is a 1/2" high precision pressure microphone set for laboratory work and coupler measurements with built-in TEDS and 5-pin LEMO connector.  
 To be used with AA0091 5-pin to 7-pin LEMO cable. A front-vented version is available, 46AG-FV.

**GRAS 46BP-1**

**1/4" LEMO Pressure Standard Microphone Set**



46BP-1 is a 1/4" LEMO microphone set for pressure measurements for measuring high sound pressure levels at high frequencies, with a 5-pin LEMO connector.  
 To be used with AA0091 5-pin to 7-pin LEMO cable.

**GRAS 46AP**

**1/2" LEMO Pressure Standard Microphone Set, High Sensitivity**



46AP is a 1/2" general-purpose pressure microphone set with built-in TEDS and 7-pin LEMO connector.

**GRAS 46DP-1**

**1/8" LEMO Pressure Standard Microphone Set**



46DP-1 is a 1/8" pressure microphone set with built-in TEDS and a 5-pin LEMO connector.  
 To be used with AA0091 5-pin to 7-pin LEMO cable.

**GRAS 46BH-1**

**1/4" LEMO Pressure Standard Microphone Set, High Pressure**



46BH-1 is a 1/4" high pressure microphone set with built-in TEDS and a 5-pin LEMO connector. With a dynamic range topping at 193 dB it is ideal for measuring at very high sound pressure levels.  
 To be used with AA0091 5-pin to 7-pin LEMO cable.

	Nominal Sensitivity	Frequency Response	Power Supply	Dynamic Range	Temperature Range	Length	Diameter without Protection Grid	Diameter with Protection Grid	Weight
46AG	12	3.15 – 20 k	28 – 120	25 dB(A) to 164 dB	-30 to +70	101	12.7	13.2	42
46AP	50	3.15 – 10 k	28 – 120	18 dB(A) to 149 dB	-30 to +70	101	12.7	13.2	42
46BH-1	0.4	10 – 20 k	28 – 120	54 dB(A) to 193 dB	-30 to +70	69	6.35	6.9	10
46BP-1	1.5	4 – 70 k	28 – 120	39 dB(A) to 172 dB	-30 to +70	69	6.35	6.9	10
46DP-1	0.9	6.5 – 140 k	28 – 120	52 dB(A) to 178 dB	-30 to +70	90	3.2	3.5	8
Units	mV/Pa	Hz	V DC	re. 20 µPa	°C	mm	mm	mm	g

# PREPOLARIZED MEASUREMENT MICROPHONES

## FREE FIELD AND RANDOM INCIDENCE

### GRAS 40AE

#### 1/2" Free-field Microphone



General-purpose high-sensitivity microphone with a frequency range from 3.15 Hz to 20 kHz. Requires no external polarization voltage. Ideal with CCP preamplifiers, Type 1 sound level meters and other similar measurement setups.

### GRAS 40AZ

#### 1/2" Free-field Microphone, Low Frequency



Low-frequency microphone especially designed for infra-sound measurements. Frequency range from 0.5 Hz to 20 kHz. Use the dedicated 26CG 1/4" CCP preamplifier in order to obtain the low frequency response.

### GRAS 40AM

#### 1/2" Free-field Microphone, Wide Frequency



High-precision microphone for laboratory work. Wide frequency range from 3.15 Hz to 31.5 kHz. Its size and low sensitivity make it extremely robust and stable and it can measure sound levels up to 163 dB.

### GRAS 40BE

#### 1/4" Free-field Microphone



Low-sensitivity microphone for high level and high frequency measurements. Requires no polarization voltage. Its low sensitivity makes it ideal for measuring high sound-pressure levels up to 168 dB. Ideal with CCP preamplifiers and for sound measurements at very high frequencies and levels.

*A front-vented version is available, 40BE-FV.*

### GRAS 40AQ

#### 1/2" Random-incidence Microphone



High-sensitivity microphone with a frequency response optimized to measure sound correctly in random, diffuse and reverberant sound fields. Requires no external polarization voltage. It fulfills the requirements of ANSI standard S1.4.

	Size	Application	Sensitivity	Dynamic Range	Frequency Range	Polarization Voltage	IEC 61094 Designation
40AE	12.7 (1/2")	Free field	50	15 – 148	3.15 – 20 k	0	WS2F
40AM	12.7 (1/2")	Free field	14.5	20 – 163	3.15 – 31.5 k	0	WS2F
40AQ	12.7 (1/2")	Random	50	16 – 148	3.15 – 12.5 k	0	WS2P/D
40AZ	12.7 (1/2")	Free field	50	14 – 148	0.5 – 20 k	0	WS2F
40BE	6.35 (1/4")	Free field	4	30 – 168	4 – 80 k	0	WS3F
Units	mm (housing)		mV/Pa	dB re. 20 µPa	Hz	V	

**GRAS 40AD**

**1/2" Pressure Microphone, High Sensitivity**



A high-sensitivity microphone with a frequency range from 3.15 Hz to 10 kHz. Requires no external polarization voltage. Can measure sound pressure levels down to 16 dB(A). May also be used as a random-incidence microphone.

*A front-vented version is available, 40AD-FV.*

**GRAS 40BD**

**1/4" Pressure Microphone**



Its low sensitivity makes it ideal for measuring high sound pressure levels up to 166 dB. Its small size reduces the effects of diffraction around the microphone, resulting in a frequency range extending up to 70 kHz.

*A front-vented version is available, 40BD-FV.*

**GRAS 40AO**

**1/2" Pressure Microphone, Wide Frequency**



A high precision microphone for laboratory work. Has a frequency range from 3.15 Hz to 20 kHz. Requires no external polarization voltage. Its size and lower sensitivity make it extremely robust and stable and it can measure sound pressure levels up to 163 dB.

*A front-vented version is available, 40AO-FV.*

**GRAS 40DD**

**1/8" Pressure Microphone**



Low sensitivity microphone for sound measurements at high frequencies and high levels. Its low sensitivity makes it ideal for measuring high sound pressure levels of up to 175 dB. Its very small size reduces the effects of diffraction and reflections around the microphone, resulting in a frequency range extending up to 70 kHz.

	Size	Application	Sensitivity	Dynamic Range	Frequency Range	Polarization Voltage	IEC 61094 Designation
40AD	12.7 (1/2")	Pressure	50	16 – 148	3.15 – 10 k	0	WS2P
40AO	12.7 (1/2")	Pressure	12.5	25 – 163	3.15 – 20 k	0	WS2P
40BD	6.35 (1/4")	Pressure	1.6	40 – 174	4 – 70 k	0	WS3P
40DD	3.16 (1/8")	Pressure	0.9	49 – 175	6.5 – 70 k	0	–
Units	mm (housing)		mV/Pa	dB re. 20 µPa	Hz	V	

# EXTERNALLY POLARIZED MEASUREMENT MICROPHONES

FREE FIELD, RANDOM INCIDENCE AND PRESSURE

## GRAS 40AF

### 1/2" Free-field Microphone



General-purpose high-sensitivity microphone with a frequency range from 3.15 Hz to 20 kHz. Can measure sound pressure levels down to 14 dB(A). For Type 0 and Type 1 measurements.

## GRAS 40AC

### 1/2" Free-field Microphone, Wide Frequency



High-precision microphone for laboratory work and as a working standard microphone in calibration laboratories. Wide frequency range from 3.15 Hz to 40 kHz. Its size and low sensitivity make it extremely robust and stable and can measure sound levels up to 164 dB.

## GRAS 40AN

### 1/2" Free-field Microphone, Low Frequency



High-sensitivity microphone ideal for measuring sound at frequencies down to 0.5 Hz. This microphone is the obvious choice for infra-sound measurement. Use the dedicated 26HG 1/4" preamplifier in order to obtain the low frequency response.

## GRAS 40AR

### 1/2" Random-incidence Microphone



High-sensitivity microphone with a frequency response optimized to measure sound correctly in random, diffuse and reverberant sound fields. It fulfills the requirements of ANSI standard S1.4.

## GRAS 40BF

### 1/4" Free-field Microphone



Low sensitivity microphone for high level and high frequency measurements. Its low sensitivity makes it ideal for measuring high sound pressure levels of up to 172 dB. Its small size reduces the effects of diffraction and reflections around the microphone, resulting in a frequency range reaching up to 100 kHz.

## GRAS 40EN

### 1" Pressure Microphone



High precision microphone for laboratory work. Ideal for measurements in couplers, e.g., the RA0075 NBS 9-A 6cc Coupler for testing earphones according to ANSI S3.7 – 1995 and RA0113 which is a 2cc IEC 60318-5 (60126) Coupler. Can also be flush mounted to measure sound pressures on walls and boundaries.

	Size	Application	Sensitivity	Dynamic Range	Frequency Range	Polarization Voltage	IEC 61094 Designation
40AF	12.7 (1/2")	Free field	50	14 – 149	3.15 – 20 k	200	WS2F
40AC	12.7 (1/2")	Free field	12.5	20 – 164	3.15 – 40 k	200	WS2F
40AN	12.7 (1/2")	Free field	50	14 – 149	0.5 – 20 k	200	WS2F
40BF	6.35 (1/4")	Free field	4	30 – 172	4 – 100 k	200	WS3F
40AR	12.7 (1/2")	Random	50	14 – 149	3.15 – 12.5 k	200	WS2P/D
40EN	23.77 (1")	Pressure	50	9.6 – 146	2.6 – 8 k	200	WS1P
Units	mm (housing)		mV/Pa	dB re. 20 µPa	Hz	V	

**GRAS 40AG**

**1/2" Pressure Microphone**



High precision microphone for laboratory work and coupler measurements (e.g., in the RA0039 IEC 60318-1 (60318) Ear Simulator). Has a frequency range from 3.15 Hz to 20 kHz. Its size and low sensitivity makes it extremely robust and stable and it can measure sound pressure levels up to 164 dB.

**GRAS 40AP**

**1/2" Pressure Microphone, High Sensitivity**



High-sensitivity microphone with a frequency range from 3.15 Hz to 10 kHz. Can measure sound pressure levels down to 16 dB(A). May also be used as a random-incidence microphone. *A front-vented version is available, 40AP-FV.*

**GRAS 40BP**

**1/4" Pressure Microphone**



Low sensitivity microphone for sound measurements at high levels and high frequencies. Its low sensitivity makes it ideal for measuring high sound pressure levels of up to 169 dB. Its small size reduces the effects of diffraction and reflections around the microphone, resulting in a frequency range extending up to 70 kHz. *A front-vented version is available, 40BP-FV.*

**GRAS 40BH**

**1/4" Pressure Microphone, High Pressure**



Low sensitivity microphone for sound measurements at very high levels. Its very low sensitivity makes it ideal for measuring very high sound pressure levels up to 193 dB. Its small size reduces the effects of diffraction and reflections around the microphone, making it ideal for pulse measurements in frequencies up to 20 kHz.

**GRAS 40AU-1**

**1/2" Ext. Polarized Reference Pressure Microphone**



The 40AU-1 is a IEC 61094 LS2aP 1/2" externally polarized laboratory standard reference microphone that is rear-vented and ideal for precision sound pressure measurements. It has a front cavity as specified in IEC 61094-1 and it is factory calibrated and delivered with a calibration chart stating its open-circuit sensitivity and pressure frequency response.

**GRAS 40DP**

**1/8" Pressure Microphone**



Low sensitivity microphone for sound measurements at high frequencies and high levels. Its low sensitivity makes it ideal for measuring high sound pressure levels up to 178 dB. Its very small size reduces the effects of diffraction and reflections around the microphone, resulting in a frequency range extending up to 140 kHz.

	Size	Application	Sensitivity	Dynamic Range	Frequency Range	Polarization Voltage	IEC 61094 Designation
40AG	12.7 (1/2")	Pressure	12.5	25 – 160	3.15 – 20 k	200	WS2P
40AU	12.7 (1/2")	Pressure	12.5	20 – 164	3.15 – 20 k	200	LS2aP
40BP	6.35 (1/4")	Pressure	1.6	34 – 169	4 – 70 k	200	WS3P
40AP	12.7 (1/2")	Pressure	50	16 – 149	3.15 – 10 k	200	WS2P
40BH	6.35 (1/4")	Pressure	0.4	54 – 193	10 – 20 k	200	WS3P
40DP	3.16 (1/8")	Pressure	1	49 – 178	6.5 – 140 k	200	-
Units	mm (housing)		mV/Pa	dB re. 20 µPa	Hz	V	

## GRAS 40AK

### 1/2" Ext. Polarized Intensity Microphone Kit



Complete kit of the 40AI phase-matched 1/2" Intensity Microphone pair, solid spacers and adapters for a pair of 26AA 1/4" Preamplifiers.

The microphones have a free-field response optimized for use in face-to-face configuration and a high sensitivity to enable low level measurements. As a pair, they fulfill the phase requirements for Class 1 intensity microphones in accordance with IEC International Standard 61043.

The solid spacers are for intensity probe configurations using microphone separations of 12 mm, 25 mm, 50 mm and 100 mm to cover a full frequency range from 50 Hz to 10 kHz, and improve microphone protection even under the most adverse of measurement conditions.

Included are two right-angled adapters and one straight adapter for use with the 26AA 1/4" Preamplifier pair.

## GRAS 40BI

### 1/4" Ext. Polarized Intensity Microphone Kit



Complete kit of two phase-matched 1/4" intensity microphones, solid spacers and adapters for a pair of 26AA 1/4" Preamplifiers. Used for measuring very high intensity levels which exceed the dynamic range of 1/2" intensity microphones (i.e., 40AI) or in situations where space is limited. The microphones have a free-field response optimized for use in face-to-face configuration. As a pair, they fulfill the phase requirements for Class 2 intensity microphones in accordance with IEC 61043.

The solid spacers are for configurations using microphone separations of 6 mm, 12 mm and 25 mm. The 6 mm spacer alone will cover a frequency range from 500 Hz to 20 kHz, and improves microphone protection even under the most adverse conditions. Included are two right-angled adapters and one straight adapter for use with the 26AA 1/4" Preamplifier Set.

*A prepolarized version is available, 40BI-S1.*

## GRAS 40AI

### 1/2" Ext. Polarized Intensity Microphone Pair

A pair of 1/2" phase-matched Intensity Microphones as used in 40AK, but without spacers and adapters.



## GRAS 40GI

### 1/2" Pre-polarized Intensity Microphone Pair

A pair of 1/2" pre-polarized intensity microphones as used in 40GK, but without spacers and adapters.



## GRAS 40GK

### 1/2" Pre-polarized Intensity Microphone Kit



Complete kit of two phase-matched 1/2" pre-polarized intensity microphones, solid spacers and adapters for a pair of 26CB 1/4" CCP preamplifiers.

These pre-polarized microphones have a free-field response optimized for use in face-to-face optimized intensity probes. As a pair, they fulfill the phase requirements for Class 1 intensity microphones in accordance with IEC 61043.

The solid spacers are for intensity probe configurations covering a full frequency range from 50 Hz to 10 kHz using microphone separations of 12 mm, 25 mm, 50 mm and 100 mm. Two right-angled adapters and one straight adapter for use with the 26CB 1/4" CCP preamplifiers are included.

Specifications	40AI/40AK	40BI/40BI-S1	40GI/GK	Units
Sensitivity	25	4	12.5	mV/Pa
Dynamic Range	20 – 157	35 – 172	27 – 163	dB re. 20 µPa
Frequency Response	IEC 60651 Type 0	IEC 60651 Type 0	IEC 60651 Type 0	
Phase Response	IEC 61043 Class 1	IEC 61043 Class 2	IEC 61043 Class 1	
Polarization Voltage	200	200/0	0	V
Diameter	13.2	6.9	13.2	mm

# Production Line Microphones

## Production Line Microphones

In production line testing, precision and reliability are critical to ensuring that every finished product meets the high-quality standards set during R&D. This process not only safeguards your brand's reputation but also ensures that substandard units never reach the hands of end users.

## Microphones Designed with Insight

At GRAS, we understand the unique demands of production environments. Our production line microphones are engineered to deliver accurate and repeatable measurements every day, even under the pressure of high-volume testing. Balancing performance and affordability, they offer the best combination of cost-effectiveness and quality, making them ideal for large-scale deployments.

## Deliver Quality, Avoid Downtime

Streamlined production line testing is essential to maintain efficiency and avoid delays. That's why GRAS microphones are designed to be robust, reliable, and easy to integrate into your production setup. With our solutions, you can trust that every product leaving your facility will meet specifications and deliver exceptional performance to your customers.

## GRAS EQset Technology for Production Lines

GRAS has integrated its revolutionary EQset technology into the 40PM and 40PO production-line microphone families, delivering the latest in test innovation and maximum measurement reliability.



## GRAS 40PM & GRAS 40PM-1

### EQset™ Miniature Production Line Microphones



The 40PM is the ideal microphone for production line applications requiring precise acoustic measurements. For even greater accuracy up to 20 kHz or enhanced high-SPL handling, the upgraded 40PM-1 is the perfect choice. Both models feature a compact design, making them well-suited for tight spaces. Their small aperture allows for accurate near-field testing of miniature speakers, microphones, and other close-proximity sound sources.

With revolutionary EQset technology, these microphones offer minimal sensitivity deviation and an exceptionally flat frequency response with tight tolerances. This enhances test reliability while reducing the need for frequent acoustic calibration.

## GRAS 40PO-L & GRAS 40PO-H

### High Frequency EQset™ Production Line Microphones



The GRAS 40PO-L and 40PO-H are 1/4" high-frequency pressure microphones designed for production line testing, capable of precise measurements up to 40 kHz. The 40PO-L is optimized for low sound pressure levels, while the 40PO-H is designed for applications requiring a higher dynamic range.

As the first production line microphones capable of handling ultrasound measurements, they set a new standard for environmental stability. With EQset™ technology, they feature an exceptionally flat frequency response with tight tolerances and a fixed sensitivity, ensuring that all microphones of the same type perform virtually identically.



Specifications	40PM	40PM-1	40PO-L	40PO-H
Sensitivity at 250 Hz ( $\pm 0.2$ dB)	25 mV/Pa	20 mV/Pa	25 mV/Pa	8 mV/Pa
<b>Dynamic Range</b>				
Lower limit	< 30 dB(A) re. 20 $\mu$ Pa	< 30 dB(A) re. 20 $\mu$ Pa	30 dB(A) re. 20 $\mu$ Pa	36 dB(A) re. 20 $\mu$ Pa
Upper limit	120 dB re. 20 $\mu$ Pa	125 dB re. 20 $\mu$ Pa	128 dB re. 20 $\mu$ Pa	138 dB re. 20 $\mu$ Pa
<b>Frequency Range</b>				
$\pm 0.5$ dB	20 Hz – 10 kHz	20 Hz – 20 kHz	10 Hz - 25 kHz	10 Hz - 25 kHz
$\pm 1$ dB	-	-	10 Hz - 40 kHz	10 Hz - 40 kHz
$\pm 2$ dB	10 kHz – 20 kHz	-	-	-

## GRAS 40PP-10

### Free-field Production Line Microphone



▼  
The GRAS 40PP-10 is a robust and cost-effective microphone designed for production line testing of loudspeakers and acoustic transducers. It ensures an acoustically correct setup with minimal disturbance to the acoustic field and the device under test. The 40PP-10 features a long body with a BNC connector.

## GRAS 40PP-10-S1

### Free-field Production Line Microphone, High Pressure



▼  
This high-pressure version of the 40PP-10 is a robust and cost-effective microphone with an upper dynamic range limit of 142 dB. It is specifically designed for production line testing of loudspeakers, acoustic transducers, drivers, receivers, and micro speakers.

Specifications	40PP-10	40PP-10-S1
Sensitivity at 250 Hz	50 mV/Pa	9 mV/Pa
Dynamic Range		
Lower limit	< 33 dB(A) re. 20 µPa	< 33 dB(A) re. 20 µPa
Upper limit	128 dB re. 20 µPa	142 dB re. 20 µPa
Frequency Range		
± 1.5 dB	50 Hz – 5 kHz	50 Hz – 5 kHz
± 2 dB	10 Hz – 20 kHz	10 Hz – 20 kHz

# EQset Technology:

## Lower Cost, Higher Quality in Production Line Testing

EQset technology is available in the GRAS 40PM, 40PM-1, 40PO-L and 40PO-H Production Line Microphones.

Production line microphones with EQset technology are cost-effective and offer superior environmental stability, enhanced accuracy, and simplified test setup compared to traditional microphones. EQset microphones all have a uniformly fixed sensitivity and a flat frequency response. This reduces measurement uncertainty and greatly simplifies microphone setup, monitoring, replacement, and corrections. EQset means that microphone setup and replacement can happen quickly and easily without any individual microphone adjustments or corrections.

### EQset Concept

EQset is a technology developed by GRAS, incorporating a digital signal processing (DSP) module directly into the microphone. This DSP module equalizes the microphone's frequency response and sets its sensitivity, ensuring that all microphones of the same type have a uniformly fixed sensitivity and flat frequency response with tight tolerances. As a result, these microphones are as identical to each other as techni-

cally possible, minimizing measurement uncertainty and significantly simplifying the signal path setup. With EQset, everything is streamlined—no individual microphone adjustments or corrections are needed. This accelerates setup time, streamlines the test process, and enhances the reliability of test results.

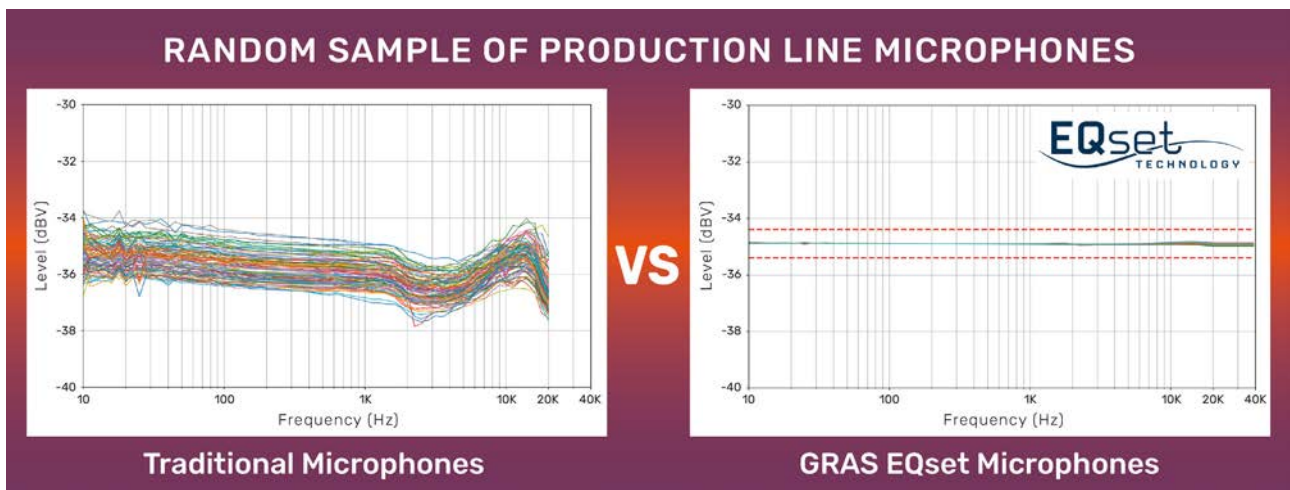

### Features and Benefits

- Price competitive
- No individual sensitivity adjustment required
- Flat frequency response
- Minimize measurement error / uncertainty
- All microphones of the same type are interchangeable
- Easy set up with no hassle (plug & play)
- Environmentally stable
- TEDS compatible (40PO-L/H)
- Can be powered with +48V phantom power
- Compact size
- SMB connector allows for easy and reliable connection and disconnection
- Bar-code for easy sensor identification

**EQset**  
TECHNOLOGY

## Environmental Stability

The sensitivity deviation of EQset microphones on a typical production line\* is less than  $\pm 0.1$  dB (40PO-L/H),  $\pm 0.2$  dB (40PM-1) and  $\pm 0.3$  dB (40PM) despite changes in temperature, static pressure, and relative

humidity. This means there is no need for corrections due to environmental changes over the course of a normal day in a typical production-line environment.

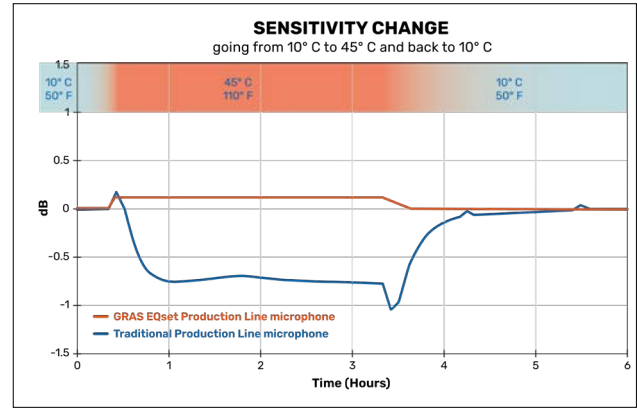
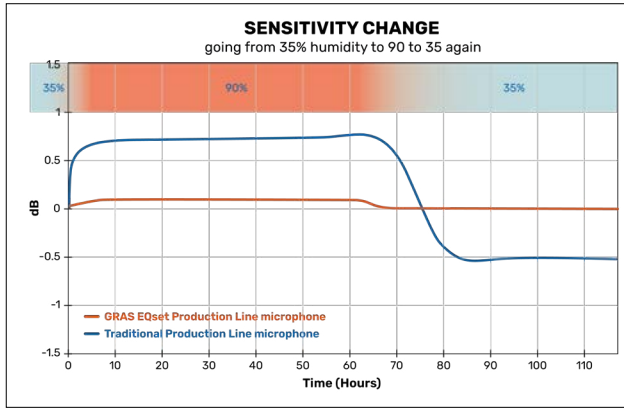

\*Typical environmental conditions on a production line are defined by temperature varying between 13 and 35°C (55 to 95°F), static pressure varying between 983 and 1043 hPa, and non-condensing humidity.

## Trust your Test Results

Traditional production line microphones often show inconsistent sensitivity and frequency response, leading to unreliable test results and potential false passes or failures. GRAS EQset microphones offer

precise frequency response, stable sensitivity, and high environmental stability, ensuring reliable testing, reducing production costs, and protecting your brand's reputation.

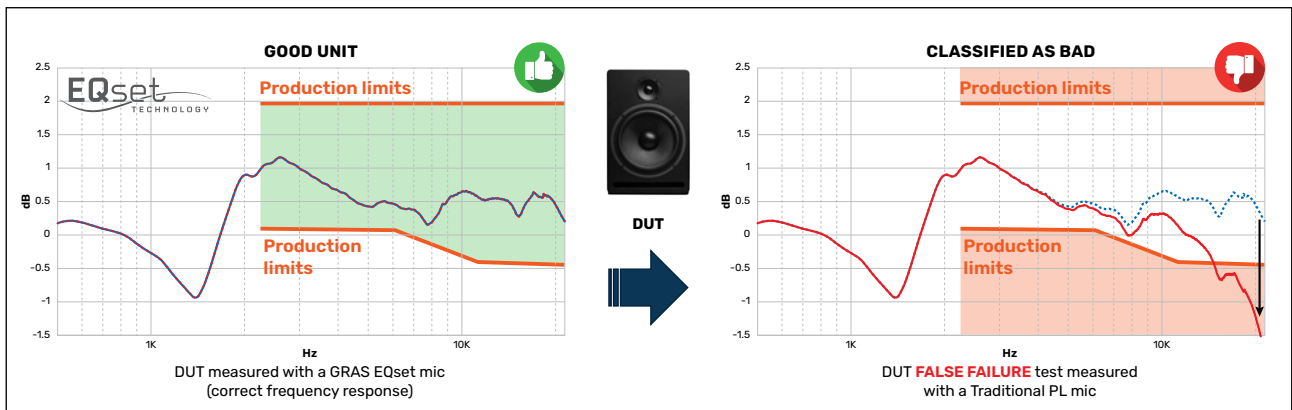

A good unit (e.g.: loudspeaker) may fail testing and be discarded due to inaccuracies in the frequency response of traditional production line microphones (False Failure). Also, a defective unit might incorrectly pass testing and be classified as functional (False Pass).



# Special Microphones

Special microphones are often required for applications where there are particular requirements surrounding the methods of measurements and configurations.

**Surface microphones** The GRAS surface microphones are specifically designed for in-situ boundary layer testing, where non-intrusive mounting is essential. This eliminates the need to drill holes at the mounting location. Their low-profile design minimizes height, and they can be installed with a surrounding fairing to reduce self-generated turbulence. Equipped with an integrated preamplifier, they offer true plug-and-play functionality.

The 40PS-1 model features a cost-effective microphone capsule and is 2.8 mm thick. The 40LA and 40LS models use high-precision microphone capsules, with a reduced thickness of 2.5 mm. The 48LA and 48LX Ultra-Thin-Precision (UTP) microphones leverage cutting-edge manufacturing techniques, enabling a high-quality condenser microphone to fit into an ultra-slim 1 mm housing, while ensuring the solution remains cost-effective.

GRAS surface microphones are engineered for quick, easy mounting and rapid in-situ verification. They are ideally suited for boundary layer measurements, aeroacoustic testing, and applications involving small cavity measurements.

**Array microphones** are for situations where concurrent measurements are required at several points in an array.

For example in the analyses of:

- ✓ Sound fields
- ✓ Sound power
- ✓ Transients

Close manufacturing tolerances together with the advantages of TEDS provide GRAS array microphones with a high degree of interchangeability. This is a major advantage when they are used in multiples forming arrays and matrices. All have a coaxial SMB output connector.

**Flush-mount microphones** have very low installation height to fit the sensors into very confined spaces and narrow structures, e.g., in acoustic antennas and beams. With an installation height of less than 10 mm and thin coax wiring, the GRAS flush-mount series can be integrated into literally any design without sacrificing aerodynamic properties. Flush-mount accessories are available for these microphones, and will require drilling a hole on the mounting structure.

**Probe microphones** are for measurements in difficult or inaccessible situations, for example at high temperatures or in conditions of airflow. Their right-angled design makes them particularly well suited for measurements in exhaust systems and machinery in general, as well as for scanning surfaces such as loudspeakers and cabinets. The small size, low weight and all stainless steel design of the probe's tip make it robust, durable, easy to handle and simple to mount.

**Turbulence Screens** are for aeroacoustic testing in solid-walled wind tunnels. The hydrodynamic component of turbulence is attenuated up to 25 dB. Thereby the acoustic signals of interest can be identified and diagnosed with a reliable resolution.

**Ground array microphone** kits are developed for fixed-wing aircraft and rotorcraft flyover measurements in phased arrays, where the noise is mapped for research or approval purposes. They offer a practical alternative to the conventional upside-down microphone setup.

**Infra-sound microphones** have a very low low-frequency cut-off down to 0.09 Hz. They consist of a special microphone combined with a special preamplifier and a low-frequency adapter. To account for pressure variations close to 0 Hz, a special ambient pressure equalization system is used.

**GRAS hemisphere kits** are compliant with the ISO 3744, 3745 and 3746 (ANSI S12.54, S12.55, S12.56) standards for sound power measurements and accommodate for 4, 10 and 20 microphone positions.

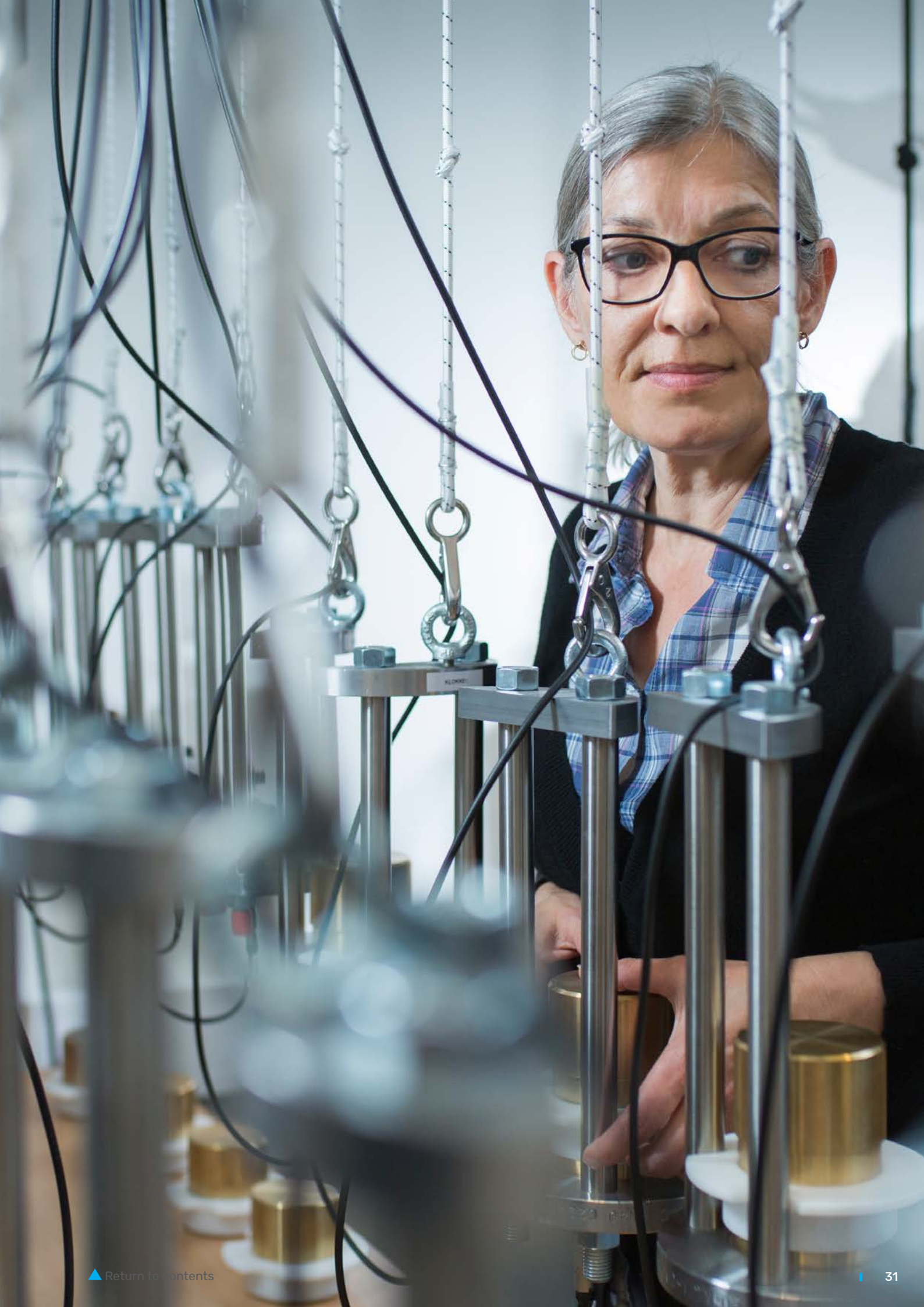

## UTP - Ultra Thin Precision surface microphones



### GRAS 48LA

#### UTP Microphone, High Pressure



48LA is a UTP high-pressure surface microphone for aeroacoustic testing.

It is a revolutionary new design that has made it possible to combine a 1/4" condenser microphone with a form factor that makes it the world's smallest measurement microphone.

The height of the microphone is 1 mm. It has a built-in preamplifier. The integrated cable connector is Microdot male. The total cable length is 3 m.

### GRAS 48LX-1

#### UTP Microphone, Medium Pressure



48LX-1 is a UTP surface microphone set for aeroacoustic testing.

It is a 1/4" CCP medium-pressure condenser microphone set with a height of 1 mm.

The microphone set includes a preamplifier with TEDS.

The integrated cable connector is Microdot female. The total cable length is 3 m.

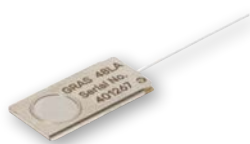

Specifications	48LA	48LX-1
Nominal Sensitivity	0.12 mv/Pa ( $\pm 2$ dB)	0.6 mv/Pa at 250 Hz
Frequency Range	20 Hz – 20 kHz ( $\pm 1$ dB) 16 Hz – 31.5 kHz ( $\pm 3$ dB)	20 Hz – 40 kHz ( $\pm 1$ dB) 10 Hz – 70 kHz ( $\pm 3$ dB)
Dynamic Range	64 dB(A) – 184 dB re. 20 $\mu$ Pa	54 dB/(A) – 170dB re. 20 $\mu$ Pa
Output connector	Microdot 10/32 (male)	Microdot 10/32 (female)
Temperature Range	-20°C to +85°C	-20°C to +85°C
Output Impedance	< 50 $\Omega$	< 50 $\Omega$
Diameter with fairing	29	29
Thickness	1 mm	1 mm
Weight	1 g	1 g
Cable Length	3 m	3 m

## Surface Microphones



### GRAS 40LS

#### CCP Precision Surface Microphone

40LS is a high-precision microphone for measurements on airplane surfaces, vehicle surfaces, critical measurements in wind-tunnel as well as general measurements on planar and curved surfaces. It has a wide frequency range reaching up to 70 kHz and a large dynamic range topping at around 167 dB.

40LS is based on high performance measuring microphone technique, which makes the microphone very precise, robust and reliable. The microphone is an integrated unit consisting of the microphone capsule itself and a CCP preamplifier including TEDS for easy access of identification data and calibration data.

### GRAS 40LA

#### CCP Precision Surface Microphone, High Pressure

40LA is a high-precision surface microphone with a very low sensitivity 0.5 mV/Pa (178 dB).

### GRAS 40PS-1

#### CCP Surface Microphone



40PS-1 Surface Microphone is a low-profile, light surface microphone for general-purpose measurements on planar and curved surfaces exposed to slipstreams.

Specifications	40LA	40LS	40PS-1
Nominal Sensitivity	0.5 mV/Pa	1.8 mV/Pa at 250 Hz	15 mV/Pa at 250 Hz
Frequency Range	10 Hz – 20 kHz ( $\pm 1$ dB) 5 Hz – 70 kHz ( $\pm 3$ dB)	10 Hz – 20 kHz ( $\pm 1$ dB) 5 Hz – 70 kHz ( $\pm 3$ dB)	10 Hz – 12 kHz (+1, -2 dB) 10 Hz – 20 kHz (+1, -6 dB)
Upper Limit of Dynamic Range	178 dB re. 20 $\mu$ Pa	167 dB re. 20 $\mu$ Pa	145 dB re. 20 $\mu$ Pa
Output connector	Microdot 10/32	Microdot 10/32	Microdot 10/32
Lower Limit of Dynamic Range	< 56 dB(A) re. 20 $\mu$ Pa (thermal noise)	< 46 dB(A) re. 20 $\mu$ Pa (thermal noise)	< 27 dB(A) re. 20 $\mu$ Pa (thermal noise)
Temperature Range	-55°C to +100°C	-50°C to +100°C	-0°C to +50°C
Output Impedance	< 50 $\Omega$	< 50 $\Omega$	< 50 $\Omega$
Diameter (with fairing) (without fairing)	42 mm 16.2 mm	42 mm 16.2 mm	40 mm 12.5 mm
Thickness	2.5 mm	2.5 mm	2.8 mm
Weight	3 g	3 g	1.5 g
Cable Length	1.5 m	1.5 m	2 m
Cable Diameter	1.1 mm	1.1 mm	1.1 mm

## GRAS 47AX

### 1/2" CCP Flush-Mount Microphone Set



47AX is a low profile 1/2" precision pressure microphone set with built-in CCP preamplifier. With a height (to the diaphragm) of only 8 mm, 47AX is suitably designed for flush mounting in plates in ground array applications and other applications with size constraints.

## GRAS 47BX

### 1/4" CCP Flush-Mount Microphone Set



47BX is a low profile 1/4" precision pressure microphone set with built-in CCP preamplifier. With a height (to the diaphragm) of only 8 mm, 47BX is suitably designed for flush mounting in plates in ground array applications and other applications with size constraints.

## GRAS 47AD

### 1/2" CCP Flush-mount Microphone Set High Sensitivity



Identical to 47AX, but with higher sensitivity—see specifications below.

## GRAS 47BG-FV

### 1/4" CCP Miniature Flush-mount Microphone set, High Pressure



A front-vented 1/4" CCP pressure microphone set for measuring very high sound pressure levels using flush mounting and where mounting space is limited or restrictive.

Specifications	47AX	47BX
Nominal Sensitivity	12.5 mV/Pa at 250 Hz	1.6 mV/Pa at 250 Hz
Frequency Response	3.15 Hz – 20 kHz (± 2.0 dB) 5 Hz – 12.5 kHz (± 1.0 dB)	4 Hz – 70 kHz (± 2.0 dB) 10 Hz – 25 kHz (± 1.0 dB)
Dynamic Range	22 dB(A) to 150 dB	44 dB(A) to 166 dB
Temperature	- 30°C to + 70°C (operation) - 40°C to + 85°C (storage)	- 30°C to + 70°C (operation) - 40°C to + 85°C (storage)
Static pressure coefficient @250 Hz	-0.008 dB/kPa	-0.008 dB/kPa
Dimensions	Diameter; Microphone: 12 mm—Preamplifier: 18 mm	Diameter; Microphone: 6 mm—Preamplifier: 18 mm
Height of Microphone Set	With grid: 9.2 mm / Without grid: 8 mm	With grid: 9.1 mm / Without grid: 8 mm
Weight	9 g	7.5 g

Specifications	47AD	47BG-FV
Nominal Sensitivity	50 mV/Pa at 250 Hz	0.23 mV/Pa at 250 Hz
Frequency Response	3.15 Hz – 10 kHz (± 2.0 dB) 12.5 Hz – 7 kHz (± 1.0 dB)	3.15 Hz – 60 kHz (± 2.0 dB)
Dynamic Range	18 dB(A) to 138 dB	60 dB(A) to 184 dB
Temperature	- 30°C to + 70°C (operation) - 40°C to + 85°C (storage)	- 30°C to + 85°C (operation) - 40°C to + 85°C (storage)
Static pressure coefficient @250 Hz	-0.008 dB/kPa	-0.01 dB/kPa
Dimensions	Diameter; Microphone: 12 mm—Preamplifier: 18 mm	Diameter; Microphone: 5.9 mm—Preamplifier: 14.8 mm
Height of Microphone Set	With grid: 9.2 mm / Without grid: 8 mm	With grid: 16 mm / Without grid: 14.6 mm
Weight	9 g	8 g

### GRAS 67TS-1-CL

#### 67TS-1-CL Turbulence Screen Kit with Flush-mount Microphone



67TS-1-CL Turbulence Screen Kit is designed for aero-acoustic testing in solid-walled wind tunnels. The hydrodynamic component of turbulence is attenuated up to 25 dB. Thereby the acoustic signals of interest can be identified and diagnosed with a reliable resolution. The 47BX-CL 1/4" CCP Flush-mount Microphone Set is included.

### GRAS 67TS

#### 67TS Turbulence Screen Kit



67TS Turbulence Screen Kit is identical to the 67TS-1-CL, but without microphone.



## GRAS 40SA

### LEMO Probe Microphone



Small, compact unit for sound pressure measurements in small enclosures, harsh environments and very close to sound sources. The high acoustic input impedance of the probe tip has minimal influence on the acoustic field, and can withstand temperatures of up to 800°C.

It is constructed with a detachable stainless steel probe tip that guides the acoustic signal to a microphone inside the probe housing. For closed-coupler measurements, the probe microphone uses internal pressure equalization to balance out static pressure differences.



## GRAS 40SC

### CCP Probe Microphone



Similar to the 40SA in both size and performance but differs in the way it is powered. The GRAS 40SC is built around a prepolarized microphone and CCP preamplifier and requires a constant-current power supply. It has a BNC output socket for making a connection to a constant-current power supply or a data-acquisition system that can supply constant current between 2 and 20 mA.

Both probe types are delivered with a selection of probe tips of various lengths that can be customized with the supplied set of pliers.

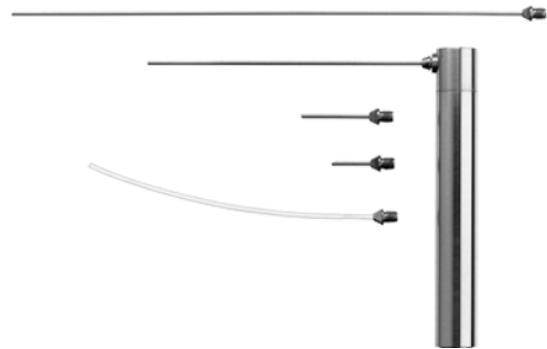

	Sensitivity at 250 Hz	Dynamic Range	Frequency Range ( $\pm 3$ dB)	Electrical Output Impedance	Noise Floor (typical)	
					A-weighted	Lin (20 Hz – 20 kHz)
40SA	3	40 to > 166	2 – 8 k	55	6	2
40SC	3	40 to > 160	2 – 8 k	< 50	6	3
Units	mV/Pa (nom.)	dB re. 20 $\mu$ Pa	Hz	$\Omega$	$\mu$ V	$\mu$ V

## GRAS 46AN

### 1/2" LEMO Free-field Standard Microphone Set, Low Frequency



High-sensitivity microphone ideal for measuring sound at frequencies down to 0.5 Hz. This microphone is the obvious choice for infra-sound measurement. It has built-in TEDS and a 7-pin LEMO connector.

## GRAS 47AC

### 1/2" CCP Infra-Sound Microphone Set



47AC is a 1/2" CCP free-field microphone set optimized for infra-sound measurements down to 0.09 Hz.

## GRAS 46AZ

### 1/2" CCP Free-field Standard Microphone Set, Low Frequency



Low frequency microphone especially designed for infra-sound measurements. Frequency range from 0.5 Hz to 20 kHz. Use the dedicated GRAS 26CG 1/4" CCP preamplifier in order to obtain the low frequency response.

Specifications	46AN	46AZ	47AC
Size	12.7 (1/2") mm (housing)	12.7 (1/2") mm (housing)	12.7 (1/2") mm (housing)
Application	Free field	Free field	Free field
Sensitivity	50 mV/pa	50 mV/pa	8 mV/pa
Dynamic Range	17 dB(A) – 149 dB re 20 µPa	17 dB(A) – 138 dB re 20 µPa	20 dB(A) – 148 dB re 20 µPa
Frequency Range	0.5 Hz – 20 kHz	0.5 Hz – 20 kHz	0.09 Hz – 20 kHz
Polarization voltage	200 V	0 V	0 V
IEC 61094 designation	WS2F	WS2F	WS2F

## GRAS 40PH-10

### CCP Free-field Array Microphone



Cost-effective free-field microphone for general-purpose measurements in arrays and matrices with a nominal sensitivity of 50 mV/Pa. It has a wide frequency range up to 20 kHz and a dynamic range from 33 dB(A) to 135 dB. Its integrated CCP preamplifier and built-in TEDS enables it to be used with TEDS compatible input modules.

## GRAS 40PL-10

### CCP Free-field Array Microphone, High Pressure



Cost-effective microphone for general-purpose measurements in arrays and matrices with a nominal sensitivity of 9 mV/Pa. It has a wide frequency range up to 20 kHz and a large dynamic range from 33 dB(A) to 142 dB. Its integrated CCP preamplifier and built-in TEDS enables it to be used with TEDS compatible input modules.

## GRAS 40PL-11

### CCP Free-field Array Microphone, High Pressure, Short



40PL-11 is a short version of 40PL-10. The specifications are the same, but it is only 34 mm long.

Specifications	40PH-10	40PL-10/40PL-11
Sensitivity at 250 Hz	50 mV/Pa (nominal)	9 mV/Pa (nominal)
Dynamic Range		
Lower limit	< 33 dB(A) re. 20 µPa	< 33 dB(A) re. 20 µPa
Upper limit	135 dB re. 20 µPa	142 dB re. 20 µPa
Frequency Range		
± 1.5 dB	50 Hz – 5 kHz	50 Hz – 5 kHz
± 2 dB	10 Hz – 20 kHz	10 Hz – 20 kHz
Phase match (50 Hz – 5 kHz)	±5°	±5°
Output Impedance	< 50 Ω	< 50 Ω

## GRAS 67AX

### ø40 cm CCP Ground Array Microphone Kit



The GRAS ground array kits are developed for fixed-wing aircraft and rotorcraft flyover measurements in phased arrays, where the noise is mapped for research or approval purposes.

The design offers a practical alternative to the conventional up-side-down microphone setup. They are based on customized version of the 47AX flush-mount pressure microphone set, integrated into a ø40 cm POM plate, which is easy to position and calibrate in the field.

Includes the GRAS 47AX-S1 1/2" CCP Flush-mount Microphone Set, which is a rear-vented version of 47AX.

Specifications	47AX
Nominal Sensitivity	12.5 mV/Pa at 250 Hz
Frequency Response	3.15 Hz – 20 kHz (± 2.0 dB) 5 Hz – 12.5 kHz (± 1.0 dB)
Dynamic Range	Upper limit; 150 dB re. 20 µPa (3% distortion) Thermal noise; 22 dB(A) re. 20 µPa
Temperature	- 30°C to + 70°C (operation) - 40°C to + 85°C (storage)
Static Pressure Coefficient	-0.008 dB/kPa (250 Hz / 25°C)
Dimensions	Diameter; Microphone: 12 mm—Preamplifier: 18 mm
Height of Microphone Set	With grid: 9.2 mm / Without grid: 8 mm
Weight	9 g

## Hemisphere Kits



The GRAS hemisphere kits are optimized for easy sound power testing ensuring acoustically correct and repeatable measurement data. The hemisphere kits are straightforward to assemble and it is simple to position the microphones and access the DUT. The GRAS hemispheres are compliant with the ISO 3744, 3745 and 3746 (ANSI S12.54, S12.55, S12.56) standards and accommodate for 4, 10 and 20 positions. The hemisphere kits contain the mechanical structure, microphone sets and cables.

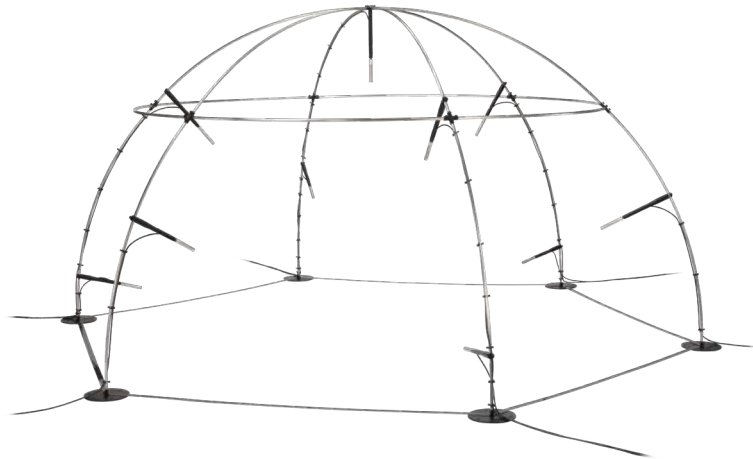

### GRAS 67HA

#### Hemisphere Kits, 1 m Radius



##### For LEMO Input

67HA-01 1 m LEMO Hemisphere Kit, 4-Channel  
 67HA-02 1 m LEMO Hemisphere Kit, 10-Channel  
 67HA-03 1 m LEMO Hemisphere Kit, 20-Channel

##### For CCP Input

67HA-04 1 m CCP Hemisphere Kit, 4-Channel  
 67HA-05 1 m CCP Hemisphere Kit, 10-Channel  
 67HA-06 1 m CCP Hemisphere Kit, 10-Channel

##### For Low-noise Applications

67HA-07 1 m LEMO Low-noise Hemisphere Kit, 4-Channel  
 67HA-08 1 m LEMO Low-noise Hemisphere Kit, 10-Channel  
 67HA-09 1 m LEMO Low-noise Hemisphere Kit,  
 20-Channel

*A pair of flight cases for 1 m hemisphere & accessories is available, RA0276.*

### GRAS 67HB

#### Hemisphere Kits, 2 m Radius



##### For LEMO Input

67HB-01 2 m LEMO Hemisphere Kit, 4-Channel  
 67HB-02 2 m LEMO Hemisphere Kit, 10-Channel  
 67HB-03 2 m LEMO Hemisphere Kit, 20-Channel

##### For CCP Input

67HB-04 2 m CCP Hemisphere Kit, 4-Channel  
 67HB-05 2 m CCP Hemisphere Kit, 10-Channel  
 67HB-06 2 m CCP Hemisphere Kit, 10-Channel

##### For Low-noise Applications

67HB-07 2 m LEMO Low-noise Hemisphere Kit, 4-Channel  
 67HB-08 2 m LEMO Low-noise Hemisphere Kit, 10-Channel  
 67HB-09 2 m LEMO Low-noise Hemisphere Kit,  
 20-Channel

*A pair of flight cases for 2 m hemisphere & accessories is available, RA0277.*

# Preamplifiers

The output from a condenser microphone is a very high impedance signal and is therefore very sensitive to the capacitive loads of cables. This makes it necessary to introduce a driver with a high input impedance and a low output impedance. Such a driver is called a preamplifier.

The frequency range of a preamplifier is determined by its electronic circuit and is typically more than 200 kHz at the high end and 1 – 10 Hz at the lower end. The lower end is determined by the input impedance of the preamplifier and the capacitance of the microphone. High microphone capacitance gives a low cut-off frequency.

The dynamic range of a preamplifier is defined as the range between the highest level the preamplifier can handle without distortion, and the lowest level it can measure. The highest level is related to the preamplifiers supply voltage, whereas the lowest level is related to the electrical noise generated by the preamplifier itself.

Today there are two different preamplifier principles in the world of acoustics.

One is the traditional type often referred to as the "LEMO" type because of its 7-pin connector which has become an industry standard. It is voltage driven and can handle high voltage signals up to 50 V<sub>peak</sub>. Add a sentence after this. Traditional LEMO type preamplifiers can be used with both externally polarized and prepolarized microphone capsules.

The other principle uses a Constant Current Power (CCP) supply and was introduced around 1996 to the world of high-precision acoustics. Before that, the quality of CCP preamplifiers was not as good as the voltage driven LEMO types, but that is not the case today. A CCP preamplifier uses a Constant Current Power supply, which must lie between 2 mA and 20 mA

(nominally 4 mA), to produce a constant nominal voltage level of 12 V DC (referred to as the bias voltage).

The output signal from the microphone superimposes fluctuations around this DC level. The great advantage of CCP preamplifiers is that they use a two wire system where the signal is superimposed on the wire through which the current is kept constant. This means that simple coaxial cables can be used instead of the more complex 7-core cables used with the voltage-driven LEMO types. This is traded off by accepting a lower upper limit in dynamic range (due to the lower driving voltage of a constant-current source) which limits the maximum output signal to approximately 8 V<sub>peak</sub>, and the fact that it can be used with prepolarized microphone capsules only.

GRAS microphone preamplifiers are all small robust units optimized for acoustical measurements with condenser microphones. They are all compatible with measurement microphones as defined in the international standard IEC 61094 "Measurement Microphones, Part 4: Specifications for working standard microphones".

All GRAS preamplifiers are built around a small, thick-film precision amplifier with very high input impedance. The casings are made of stainless steel for maximum strength and durability with minimal sensitivity to vibration and microphonics.

They will work within their specifications up to a temperature of 70°C. Special versions for use at temperatures up to 120°C are available as well. The effect of elevated temperature is a slight increase in the inherent noise level. This will change the lower limit of the dynamic range of the microphone/preamplifier combination, thus limiting the ability to measure very low sound pressure levels.

Constant Current Power (CCP) is the same as Integrated Electronic Piezo-Electric (IEPE) and Constant Current Line Drive (CCLD) and is compatible with many other constant current driven products such as Deltatron® (Brüel & Kjaer), Isotron® (Endevco Corp.), ICP® (PCB Group, Inc.).



# 1/2" TRADITIONAL LEMO PREAMPLIFIERS

## GRAS 26AG

### 1/2" LEMO Insert Voltage Preamplifier



▼ Preamplifier with an integrated 7-pin LEMO connector. Configured to permit use of the insert voltage technique for determining the open-circuit sensitivity of a microphone.

## GRAS 26AM

### 1/2" LEMO Preamplifier



▼ General-purpose preamplifier with an integrated 3 m cable terminating in a 7-pin LEMO connector.

## GRAS 26AI

### 1/2" Preamplifier with Integrated Connector, Low Frequency



▼ The 26AI is a 1/2" microphone preamplifier with integrated 7-pin LEMO male connector and 40 GΩ input impedance. It is ideal to pair with a low frequency microphone capsule such as 40AN.

## GRAS 26TK

### 1/2" Standard Preamplifier with Integrated Connector



▼ The 26TK is a 1/2" microphone preamplifier with integrated 7-pin LEMO male connector. It is the most common "go-to" preamplifier used in most applications where a Traditional LEMO preamplifier is needed. The built-in TEDS chip can be programmed when a microphone is fitted.

Specifications	26AM	26AG	26AI	26TK
Frequency Range	2.5 Hz – 200 kHz (± 0.2 dB)	2.5 Hz – 200 kHz (± 0.2 dB)	1 Hz to 200 kHz	0.5 Hz to 200 kHz
Input Impedance	20 GΩ, 0.4 pF	20 GΩ, 0.4 pF	40 GΩ, 0.4 pF	20 GΩ, 0.4 pF
Output impedance (typical)	75 Ω	75 Ω	75 Ω	75 Ω
Output Connector	7-pin LEMO male	7-pin LEMO male	7-pin LEMO male	7-pin LEMO male
Power Supply, Single	28 V, 0.7 mA to 120 V, 2.5 mA	28 V, 0.7 mA to 120 V, 2.5 mA	28 V, 0.7 mA to 120 V, 2.5 mA	28 V, 0.7 mA to 120 V, 2.5 mA
Power Supply, Dual	±14 V, 0.7 mA to ± 60 V, 2.5 mA	±14 V, 0.7 mA to ± 60 V, 2.5 mA	±14 V, 0.7 mA to ± 60 V, 2.5 mA	±14 V, 0.7 mA to ± 60 V, 2.5 mA
Noise; A-weighted	≤ 2.5 μVrms (typically 1.8 μV)	≤ 2.5 μVrms (typically 1.8 μV)	≤ 2.5 μVrms (typically 1.8 μV)	≤ 2.5 μVrms (typically 1.8 μV)
Noise; linear (20 Hz – 20 kHz)	≤ 6 μVrms (typically 3.5 μV)	≤ 6 μVrms (typically 3.5 μV)	≤ 6 μVrms (typically 3.5 μV)	≤ 6 μVrms (typically 3.5 μV)
Gain*	-0.25 dB (typical)	-0.35 dB (typical)	-0.29 dB (typical)	-0.25 dB (typical)
Operating Temperature	-30°C to +70°C	-30°C to +70°C	-30°C to +70°C	-30°C to +70°C
Storage Temperature	-40°C to +85°C	-40°C to +85°C	-40°C to +85°C	-40°C to +85°C

\* Measured with a 20 pF dummy microphone.

## GRAS 26AB

### 1/4" LEMO Preamplifier



General-purpose preamplifier with an integrated 7-pin LEMO connector. A 1/4" to 1/2" adapter, AF0008, is included, so that it can also be used with GRAS 1/2" microphones.

## GRAS 26AN

### 1/4" LEMO Insert Voltage Preamplifier



Preamplifier with an integrated 7-pin LEMO connector. Configured to permit use of the insert voltage technique for determining the open-circuit sensitivity of a microphone. A 1/4" to 1/2" adapter, GR0010, is included, so that it can also be used with GRAS 1/2" microphones.

## GRAS 26TC

### 1/4" Preamplifier with 3 m integrated Cable



The GRAS 26TC 1/4" Preamplifier is a small robust unit optimised for acoustic measurements using condenser microphones. It has a very low inherent noise level, a wide dynamic range and a frequency response from below 2 Hz to above 200 kHz.

## GRAS 26AC-1

### 1/4" LEMO Preamplifier with Integrated 5-pin Miniconnector



General-purpose preamplifier with integrated 5-pin mini-connector. A 1/4" to 1/2" adapter, GR0010, is included, so that it can also be used with GRAS 1/2" microphones. *To be used with a cable like the AA0091.*

## GRAS 26HG

### 1/4" LEMO Preamplifier, Low Frequency



Similar to 26AC but with 40 G $\Omega$  input impedance to enable low level and low frequency measurements. It has a 3 m integrated cable.

## GRAS 26AS

### 1/4" LEMO Preamplifier, Very Short



Preamplifier with an integrated 3 m lightweight cable terminating in a 7-pin LEMO connector. It is a very small unit, short enough for use in e.g., anechoic test boxes and with the KEMAR Manikin and Hearing-protector Test Fixture.

Specifications	26TC	26AB, 26AN // 26AC-1	26HG	26AS
Frequency Range	2 Hz - 200 kHz	2 Hz - 200 kHz ( $\pm 0.2$ dB)	1 Hz - 200 kHz ( $\pm 0.2$ dB)	2.5 Hz - 200 kHz ( $\pm 0.2$ dB)
Input Impedance	20 G $\Omega$ , 0.4 pF	20 G $\Omega$ , 0.4 pF	40 G $\Omega$ , 0.4 pF	20 G $\Omega$ , 0.4 pF
Output impedance (typical)	55 $\Omega$	55 $\Omega$	75 $\Omega$	75 $\Omega$
Output Connector	7-pin LEMO male	7-pin LEMO male // 5-pin LEMO male	7-pin LEMO male	7-pin LEMO male
Power Supply, Single	28 V, 0.7 mA to 120 V, 2.5 mA	28 V, 0.7 mA to 120 V, 2.5 mA	28 V, 0.7 mA to 120 V, 2.5 mA	28 V, 0.7 mA to 120 V, 2.5 mA
Power Supply, Dual	$\pm 14$ V, 0.7 mA to $\pm 60$ V, 2.5 mA	$\pm 14$ V, 0.7 mA to $\pm 60$ V, 2.5 mA	$\pm 14$ V, 0.7 mA to $\pm 60$ V, 2.5 mA	$\pm 14$ V, 0.7 mA to $\pm 60$ V, 2.5 mA
Noise; A-weighted	$\leq 2.5$ $\mu$ Vrms (typically 1.8 $\mu$ V)	$\leq 2.5$ $\mu$ Vrms (typically 1.8 $\mu$ V)	$\leq 2.5$ $\mu$ Vrms (typically 1.5 $\mu$ V)	6 (typically 4)
Noise; lin. (20 Hz - 20 kHz)	$\leq 6$ $\mu$ Vrms (typically 3.5 $\mu$ V)	$\leq 6$ $\mu$ Vrms (typically 3.5 $\mu$ V)	$\leq 6$ $\mu$ Vrms (typically 3.2 $\mu$ V)	10 (typically 8)
Gain*	-0.25 dB (typical)	-0.29 dB (typical)	-0.25 dB (typical)	-0.29 dB (typical)
Operating Temperature	-30°C to +70°C	-30°C to +70°C	-30°C to +70°C	-30°C to +70°C
Storage Temperature	-40°C to +85°C	-40°C to +85°C	-40°C to +85°C	-40°C to +85°C

\* Measured with a 20 pF dummy microphone.

## GRAS 26CA

### 1/2" CCP Preamp with BNC Connector



26CA is a CCP preamplifier with integrated BNC connector. For use with 1/2" prepolarized microphones and standard constant-current input devices. Includes built-in TEDS which enables it to be programmed as a complete unit together with a microphone.

*A high-temperature version is available, 26CA-HT.*

## GRAS 26CF

### 1/2" CCP Preamp with Gain and Filters



26CF is a CCP preamplifier with integrated BNC connector for use with 1/2" prepolarized microphones and standard constant-current input devices. It has two flush-mounted switches for selecting various combinations of gain and filtering, i.e.:

#### Gain switch settings:

0 dB—for normal microphone signals.

+20 dB—for boosting weak microphone signals.

#### Filter switch settings:

A-Weighting—as required in standard measurements.

Linear—to let the microphone signal pass unfiltered.

High-pass—to cut off unwanted low frequencies.

## GRAS 26CK

### 1/2" CCP Preamp, Very Short



26CK 1/2" Preamp is a very small preamplifier with Microdot connector. The 26CK has a very low inherent noise level, a large dynamic range, and a frequency response from 2.5 Hz to above 200 kHz.

## GRAS 26CI

### 1/2" CCP Preamp with BNC Connector, Low Frequency



26CI is optimized for low frequency use with prepolarized condenser microphones. It uses a CCP power supply (ICP®), e.g., 12AL. It has a very low inherent noise level, a large dynamic range and a frequency response from 1 Hz to above 200 kHz.

Specifications	26CA	26CA-HT	26CF	26CK	26CI
Frequency Range	2.5 Hz – 200 kHz (± 0.2 dB)	2.5 Hz – 200 kHz (± 0.2 dB)	2.5 Hz – 200 kHz (± 0.2 dB)	2.5 Hz – 200 kHz (± 0.2 dB)	1 Hz – 200 kHz (± 0.2 dB)
Input Impedance	20 GΩ, 0.4 pF	20 GΩ, 0.4 pF	20 GΩ, 0.4 pF	20 GΩ, 0.4 pF	40 GΩ, 0.4 pF
Output Impedance	50 Ω	50 Ω	50 Ω	50 Ω	50 Ω
Output Connector	BNC	BNC	BNC	Microdot	BNC
Power Supply (mA)	2 to 20 (typ. 4)	2 to 20 (typ. 4)	4 to 20 (typ. 4 mA)	2 to 20 (typ. 4)	2 to 20 (typ. 4)
Noise A-weighted	≤ 2.5 μVrms (typ. 2.0 μV)	≤ 2.5 μVrms	Typ. 10 μVrms (built-in A-weighting)	≤ 2.5 μVrms	≤ 2.5 μVrms
Noise Linear	≤ 6 μVrms (typ. 3.5 μV)	≤ 6 μVrms	Typically 8 μVrms	≤ 6 μVrms	≤ 6 μVrms
Gain*	-0.3 dB (typical)	-0.3 dB (typical)	-0.35 dB (typical)	-0.35 dB (typical)	-0.35 dB (typical)
Operating Temp.	-30°C to +85°C	-30°C to +120°C	-30°C to +85°C	-30°C to +85°C	-30°C to +85°C
Storage Temp.	-40°C to +85°C	-40°C to +85°C	-40°C to +85°C	-40°C to +85°C	-40°C to +85°C

\* Measured with a 20 pF dummy microphone.

## GRAS 26CB

### 1/4" CCP Preamp



26CB is a CCP preamplifier with integrated Microdot connector for use with 1/4" prepolarized microphones. It includes built-in TEDS which enables it to be programmed as a complete unit together with a microphone.  
*A high-temperature version is available, 26CB-HT*

## GRAS 26CG

### 1/4" CCP Preamp, Low Frequency



26CG is a CCP preamplifier with integrated Microdot connector for use with 1/4" prepolarized microphones. It includes built-in TEDS which enables it to be programmed as a complete unit together with a microphone.

## GRAS 26CC

### 1/4" CCP Preamp



26CC is a CCP preamplifier with integrated SMB connector. For use with 1/4" prepolarized microphones. For direct use on GRAS Array Modules PR0001 and PR0002 connected to constant-current input devices. Includes built-in TEDS which enables it to be programmed as a complete unit together with a microphone.

## GRAS 26CS

### 1/4" CCP Preamp, Very Short



26CS has a Microdot connector for constant-current input devices. It is a very small unit, short enough for use in e.g., anechoic test boxes and with the KEMAR Manikin and 45CA Hearing-protector Test Fixture.

## GRAS 26CT

### 1/4" CCP Standard Preamp with SMB Connector, Very Short



The GRAS 26CT 1/4" Preamp is a very short preamp optimized for use with prepolarized condenser microphones. It features an SMB connector.

Specifications	26CB	26CC	26CG	26CS	26CT
Frequency Range	2.5 Hz - 200 kHz (± 0.2 dB)	2.5 Hz - 200 kHz (± 0.2 dB)	1 Hz - 200 kHz	2 Hz - 200 kHz	2.5 Hz - 200 kHz
Input Impedance	20 GΩ, 0.4 pF	20 GΩ, 0.4 pF	40 GΩ, 0.4 pF	20 GΩ, 0.4 pF	20 GΩ, 0.4 pF
Output Impedance	< 50 Ω	< 50 Ω	< 55 Ω	< 50 Ω	< 50 Ω
Output Connector	Microdot	SMB	Microdot	Microdot	SMB
Power Supply (mA)	2 to 20 (typ. 4)	2 to 20 (typ. 4)	2 to 20 (typ. 4)	2 to 20 (typ. 4)	2 to 20 (typ. 4)
Noise A-weighted	≤ 2.5 μVrms (typ. 1.8 μV)	≤ 2.5 μVrms (typ. 2.0 μV)	≤ 2.5 μVrms (typ. 1.5 μV)	≤ 2.5 μVrms	≤ 2.5 μVrms
Noise linear	≤ 6 μVrms (typ. 3.5 μV)	≤ 6 μVrms (typ. 3.5 μV)	≤ 6 μVrms (typ. 3.5 μV)	≤ 6 μV	≤ 6 μV
Gain*	-0.35 dB (typical)	-0.35 dB (typical)	-0.35 dB (typical)	-0.45 dB (typical)	-0.45 dB (typical)
Operating Temp.	-30°C to +85°C	-30°C to +85°C	-30°C to +85°C	-30°C to +85°C	-30°C to 70°C
Storage Temp.	-40°C to +85°C	-40°C to +85°C	-40°C to +85°C	-40°C to +85°C	-40°C to 85°C

\* Measured with a 20 pF dummy microphone.

# Microphones for Outdoor Use

Unprotected measurement microphones are sensitive to environmental factors such as wind, rain and snow. This shortcoming has been eliminated by specially-designed units that protect the microphone and its diaphragm from the effects of outdoor use. Each has a windscreen, in some cases surmounted by four-pronged anti-bird spikes to prevent birds using it as a perch.

Perching birds and their excreta can seriously distort measurements or even overload the measurement equipment. Smaller birds have actually been known to nest on top of the earlier three-pronged anti-bird spikes. Hence, the introduction of the fourth, center prong.

GRAS outdoor microphones are available in the following two versions:

- For airport noise monitoring, where the measurement direction points upwards ( $0^\circ$  incidence).
- For community noise- or traffic noise measurements, where the measurement direction is in the horizontal plane ( $90^\circ$  incidence).

GRAS Sound & Vibration has more than 1500 of these units deployed all over the world, from the Arctic cold in Norway to the humid jungles of Malaysia.



## GRAS 41AM

### Outdoor Microphone, 0° incidence



For permanent outdoor installation, for example in airport noise monitoring systems. Has built-in A-weighting,  $\pm 20$  dB amplifier (for shifting the dynamic range up or down by 20 dB) and electrostatic actuator for complete check of system functionality.

GRAS 41AM is fitted with a GRAS 41AS 1/2" microphone for measurements at 0° incidence and is optimized for use with its windscreen and rain protection.



## GRAS 41CN

### Outdoor Microphone, 90° incidence



For permanent outdoor installation, for example in community noise- or traffic noise monitoring systems. Has built-in A-weighting,  $\pm 20$  dB amplifier (for shifting the dynamic range up or down by 20 dB) and electrostatic actuator for complete check of system functionality.

GRAS 41CN is fitted with a special GRAS 1/2" microphone for measurements at 90° incidence and is optimized for use with its windscreen and rain protection.

#### Included:

- AM0052 Windscreen incl. birdspike
- AM0052 Transport protection cap
- AM0038 Spanner
- AM0029 Pole adapter
- AM0033 Tripod adapter
- AE0001 LEMO plug

#### Accessories available:

- AC0001 Adapter box
- RA0009 Pistonphone adapter 41AM
- RA0041 Pistonphone adapter 41CN
- AM0009 Set of 5 foam windscreens

#### Cables:

- AA0003 3 m
- AA0002 10 m
- AA0015 100 m on cable drum
- AA0016 200 m on cable drum

Specifications	41AM and 41CN
Sensitivity	50 mV/Pa (unified)
Dynamic Range	20 – 136 dB re. 20 $\mu$ Pa / 38 – 156 dB re. 20 $\mu$ Pa (-20 dB gain)
Frequency Response	IEC 60651 type 0 / ANSI S1.4–1983 type 0 / IEC 61672 Class 1
Power supply	12 – 18 VDC
Cal. level of electrostatic actuator	90 dB at 1000 Hz
Output connector	6-pin LEMO
Pole adapter	50 mm (1.97") G 1 1/2" (ISO 228/1)
Reference direction 41AM	0° (vertical for airport noise)
Reference direction 41CN	90° (horizontal for community noise)

## GRAS 41AC

### Outdoor Microphone Kit



The 41AC is a small and handy precision outdoor microphone kit according to IEC 61672-1 and designed for unattended use in prolonged periods.

41AC can easily be configured for measurement of noise with 90 degrees of incidence, typically community noise, or—with the included correction data—for measurement of noise with 0 degrees of incidence, typically overhead aircraft.

Depending on input type, 41AC is available in three versions.

### 41AC Configurations

**GRAS 41AC-3** CCP Outdoor Microphone for Community & Airport Noise. With CCP connection and built-in TEDS for easy identification and system setup and SysCheck2 functionality for vastly simplified calibration verification.

**GRAS 41AC-4** LEMO Outdoor Microphone for Community and Airport Noise (0 V pol.) 41AC-4 uses a prepolarized microphone with a LEMO type preamplifier.

All three kits include tripod and pole-mount options and are delivered with individual calibration and correction data. *Additional windscreen, AM0378, is available as a separate item.*



Specifications	41AC-2, 41AC-3 & 41AC-4
Sensitivity	50 mV/Pa (nominal)
Dynamic Range	17 – 144 dB re. 20 $\mu$ Pa
Frequency Range	5 Hz – 20 kHz
Compliance	IEC 61672 Class 1
Polarization Voltage	200 V (41AC-2); 0 V (41AC-3 & 4)
Connector Type	7-pin LEMO (41AC-2 & 4); BNC (41AC-3)
Microphone Type and Reference Direction	See text above

# Low-noise Measuring Systems

Normal measurement microphones have a very wide dynamic range and cover most practical applications. There are however special situations where special microphones are required e.g., the measurements of very low sound pressure levels. Normal measurement microphones have a noise floor around 15 dB(A) re. 20  $\mu$ Pa in 1/3 octave bands, while the human ear is able to detect levels down to around 0 dB. In fact, the 0 dB level was originally defined as the threshold of the human hearing ability at 1 kHz.

In some applications, it is required to measure down to and below the threshold of the human ear. This is possible by using special high sensitive microphones combined with special low-noise preamplifiers.

One of the applications of such microphones may be the measurement of the sound power of high-end personal computers. These are not only used in noisy office environments but tend to move into living rooms, meeting rooms and hotel rooms. Modern smart speakers, soundbars, headphones, and headsets often incorporate active DSP, Active Noise Cancellation (ANC), and/or wireless connectivity such as Bluetooth. These components can introduce low-level hiss that is audible to the human ear, yet may go undetected by many traditional measurement microphones. In such cases, specialized low-noise microphones are required.

In order to achieve the very low noise floor of the microphone and preamplifier, these have been specially matched and adjusted together.

Low-noise measuring systems such as GRAS 40HF, 40HH and 40HT have a special preamplifier that requires a higher supply current than the one obtained from Traditional LEMO microphone power modules, therefore they must be used together with the GRAS 12HF or 12HM power modules for low-noise systems. On the other hand, GRAS 40HL can be driven with standard traditional LEMO power modules such as the GRAS 12AK or 12BC. Finally, the GRAS 47HC is GRAS' first low-noise microphone using a pre-polarized microphone capsule in combination with a CCP preamplifier and therefore can be driven with power modules such as GRAS 12AL, 12BA, among others.

The very high sensitivity of low-noise microphones means that the sound pressure level used for calibration should be limited to 94 dB to avoid overloading.

GRAS provides the RA0090 coupler that can be used with GRAS 42AA or 42AP pistonphones to reduce the calibration reference level from 114 dB to 94 dB. Also, the 42AG multifunction calibrator from GRAS provides a simpler way to perform level calibration of Low-noise systems, as it can provide a 94 dB calibration reference signal right out of the box.



## GRAS 40HF

### 1" LEMO Low-noise Microphone System



40HF has a wide dynamic range that enables measurements from below -2 dB(A) to 110 dB re. 20  $\mu$ Pa from 10 Hz to 10 kHz.

It comprises the following two specially-designed and matched components:

- High sensitive 1" microphone
- Low-noise 1" microphone preamplifier

Can be switched to operate either for pressure measurements or free-field measurements.

*Accessory: RA0095 Dehumidifier for 1" microphone.*

*A dedicated power module is required (12HF or 12HM). The specifications given on page 98 are for such a complete system.*

## GRAS 40HH

### 1/2" LEMO Low-noise Microphone System



40HH has a wide dynamic range that enables measurements from below 6.5 dB(A) to 113 dB re. 20  $\mu$ Pa from 10 Hz to 20 kHz.

It comprises the following two specially-designed and matched components:

- High sensitive 1/2" microphone
- Low-noise 1/2" microphone preamplifier

Can be switched to operate either for pressure measurements or free-field measurements.

*A dedicated power module is required (12HF or 12HM). The specifications given on page 98 are for such a complete system.*

## GRAS 40HT

### 1/2" LEMO Low-noise Microphone System



For use in confined spaces. Otherwise, specifications similar to 40HH.

It comprises the following specially designed and matched components:

- High sensitive 1/2" microphone
- Gain and filter unit
- Low-noise 1/4" microphone preamplifier with an adapter (GR0010) for the 1/2" microphone.

It can be switched to operate either for pressure measurements or free-field measurements.

*A dedicated power module is required (12HF or 12HM). The specifications given on page 98 are for such a complete system.*



## GRAS 47HC

### 1/2" CCP Low-noise Microphone System



47HC 1/2" Low-noise Microphone System measures sound pressure levels down to close to the threshold of human hearing. It is thus generally suitable for sound-power measurements on even very quiet products. Its very wide dynamic range permits measurements down to below 6.5 dB re. 20  $\mu$ Pa (in 1/3-octave bands). 47HC has TEDS.

## GRAS 40HL

### 1/2" LEMO Low-noise Microphone System



Stand-alone low-noise Microphone system for connecting directly to any analyzer input module with 7-pin LEMO. The system is calibrated as a complete unit and has a wide dynamic range that enables measurements from below 6.5 dB(A) to 110 dB re. 20  $\mu$ Pa within 10 Hz to 20 kHz.

- High-sensitivity 1/2" microphone
- Low-noise 1/2" preamplifier with built-in TEDS

*40HL is used in the 67HA and 67HB Hemisphere Kits for 4-, 10- and 20 channel low-noise measurements.*

Specifications	40HF	40HH	40HL	40HT	47HC	Units
Nominal System Sensitivity	1.1	0.8	0.85	0.8	0.45	V/Pa
Frequency Range	12.5 – 4 k	12.5 – 10 k	12.5 – 10 k	12.5 – 10 k	12.5 – 10 k	Hz $\pm$ 1 dB
	10 – 10 k	10 – 16 k	10 – 16 k	10 – 16 k	10 – 16 k	Hz $\pm$ 2 dB
	6 – 12.5 k	6 – 20 k	6 – 20 k	6 – 20 k	6 – 20 k	Hz + 2 dB, -3 dB
Dynamic Range Lower Limit	-2	6.5	6.5	6.5	6.5	dB(A) re. 20 $\mu$ Pa
Dynamic Range Upper Limit	110	113	110	113	100	dB peak

# Intensity Probes

The technique of intensity measurements is a powerful tool used for locating sound sources, order ranking them and determining the sound power emitted. The method is based on the simultaneous determination of sound pressure and particle velocity using two closely spaced, face-to-face microphones. A sound-intensity probe must maintain a well-defined acoustical spacing between the microphones with a minimum of disturbance to the sound field.

Generally speaking, the technique of intensity measurements involves determining the direction of a sound wave by detecting differences in arrival time at two closely-spaced microphones.

If the sound wave arrives first at microphone A then, a little later, at microphone B, the sound wave must be traveling in the direction from A to B. On the other hand, if it arrives first at microphone B, then it must be traveling in the opposite direction. In the case where it arrives at the two microphones at the same time, then it must be traveling in a direction perpendicular to the pair of microphones.

The ability of a pair of microphones to determine accurately small differences in arrival times depends on how small the difference is between the phase responses of the two microphones. Therefore, phase-matching is an all-important factor for a pair of intensity microphones.

The GRAS 40AI and GRAS 40BI intensity microphone pairs have been carefully manufactured and selected to have a minimum phase difference.

To ensure maximum measurement accuracy, the spacing between the microphones should be optimized for the particular measurement conditions. At low frequencies and in highly reverberant conditions, spacing should be large, whereas at high frequencies, it should be small.

The GRAS 50AI and GRAS 50GI Intensity Probes come with a selection of solid spacers for microphone separations ranging from 12 mm to 100 mm. The design of the probe enables spacers to be swapped without dismantling the probe.

The useful frequency range of a sound intensity probe depends on the phase response of the microphones and the distance between the microphones. The GRAS sound intensity probes have been designed to switch easily between different microphone spacers to cover different frequency ranges. The usable frequency ranges for the different microphone spacers are shown below for reference. In practice, these ranges can often be extended through appropriate signal-processing techniques.

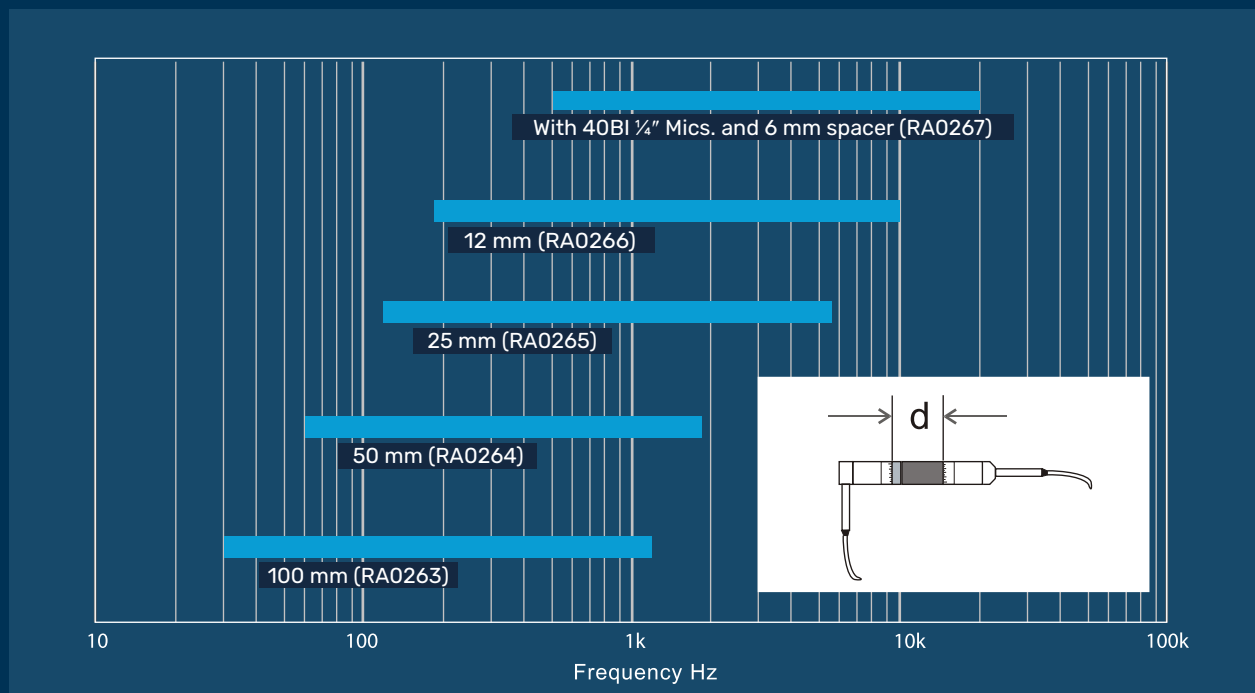



## GRAS 50AI-Series Intensity Probes



50AI Intensity Probes comprise:

- GRAS 40AK 1/2" Intensity Microphone Set
- GRAS 26AA 1/4" Preampifier Set and a remote-control handle

The remote-control functions make it possible to control the process of data acquisition entirely from the handle of the probe. Various versions of the 50AI are available with different remote-control handles for direct use with a wide range of general-purpose frequency analyzers as well as specialised sound intensity analyzers.

### GRAS 50AI-B

#### LEMO Intensity Probe



50AI-B has remote-control functions for direct connection to, and control of, sound-intensity measuring systems from a wide range of suppliers such as 01dB and Neutrix-Cortex. Can be used directly with the 12AB Intensity Power Module, which provides all necessary voltages for the remote-control functions and powering the preamplifiers; also enables direct use with 01dB Sound Intensity systems.

### GRAS 50AI-D

#### LEMO Intensity Probe



50AI-D is similar to version B, but uses an internal 9V battery (already fitted on delivery) for enabling its remote-control functions, i.e., Müller-BBM.

### GRAS 50AI-C

#### LEMO Intensity Probe



50AI-C can be connected directly to any analyzer with two standard 7-pin LEMO microphone-preampifier inputs. Can be used with the following GRAS Power Modules:

- 12AB Intensity Power Module
- 12AA Power Modules (via the included adapter cable AC0003, which splits the output from a 12-pin LEMO socket into two 7-pin LEMO plugs)

*Different adapter cables are available, see page 121.*

Specifications	50AI
Microphone pair	40AK
Preamplifiers	2 x 26AA (with 4-pin LEMO FGG 0B)
Frequency response & phase matching	IEC 61043 Class 1

## GRAS 50GI

### CCP Intensity Probe



50GI CCP Intensity Probe comprises:

- A 40 GK 1/2" Prepolarized Intensity Microphone Set
- Two 26CB 1/4" CCP Preamplifiers and a dedicated handle.

This intensity probe can be connected directly to any CCP-compatible input-module with two BNC or Microdot connectors. The prepolarized intensity microphones are phase-matched and fulfill the phase requirements for Class 1 intensity microphones in accordance with IEC 61043.

The intensity probe is designed to have as little acoustic influence as possible and allows for very near-field diagnostics of noise sources. The microphone spacers are easily interchanged without any need for extra tools and enables measurements in the area from 50 Hz to 10 kHz.

## GRAS 50GI-R

### CCP Intensity Probe with Remote Control



50GI-R CCP Intensity Probe comprises

- A 40GK sound Intensity Microphone Pair
- Two 26CB CCP Microphone Preamplifiers
- Four solid spacers of various lengths
- Windscreen
- Probe handle with remote control.

50GI-R is delivered in a carrying case as a ready-to-use kit, complete with all the above accessories. The microphones are 1/2" free-field prepolarized microphones with a uniquely-designed pressure equalization system, which ensures extremely well defined phase characteristics.

The microphones and preamplifiers are mounted on a swivel head on the telescopic arm of the Remote control handle. To cover the full frequency range from 50 Hz to 10 kHz, the 50GI-R probe is delivered with four solid spacers for spacing the microphones at 12 mm, 25 mm, 50 mm and 100 mm. These spacers can be easily interchanged without dismantling the probe.

Specifications	50GI
Microphone pair	40GK
Preamplifiers	2 x 26CB (with BNC/Microdot)
Frequency response & phase matching	IEC 61043 Class 1

## GRAS 50GI-P

### CCP Rugged Intensity Probe



The 50GI-P CCP Intensity Probe comprises a 40GK Sound Intensity Microphone Pair, two 26CB CCP Microphone Preamplifiers, three solid spacers of various lengths, windscreen and a probe handle.

The probe head is symmetrical which enables reliable calibrations as described in the proposed standard (ISO/DIS 9614-2) for sound power measurements.

50GI-P is delivered in a carrying case as a ready-to-use kit, complete with all the above accessories.

The microphones are 1/2" intensity prepolarized microphones with a uniquely-designed pressure equalization system, which ensures extremely well defined phase characteristics.

Specifications	50GI-P
Microphone pairs	40GK-S1
Preamplifiers	26CC set
Spacers	12, 25 and 50 mm
Frequency response & phase matching	IEC 61043 Class 1

## GRAS 50GI-RP

### CCP Rugged Intensity Probe with Remote Control



50GI-RP is identical to 50GI-P but with remote control buttons for start/stop of the intensity analyzer.

Specifications	50GI-RP
Microphone pairs	40GK-S1
Preamplifiers	26CC set
Spacers	12, 25 and 50 mm
Frequency response & phase matching	IEC 61043 Class 1



# Calibration Equipment

Calibration is an essential step in every precision sound measurement. It establishes the relationship between the sound pressure acting on a microphone and the resulting electrical output of the microphone. There are basically two properties of a measurement microphone requiring calibration, these are level calibration and frequency-response calibration.

Level calibration determines the absolute sensitivity of the measurement microphone. Various methods can be used, e.g., reciprocity, comparison, pistonphone or sound calibrator.

- a) Reciprocity is normally considered the most accurate method but is elaborate and expensive.
- b) Comparison is where the sensitivity of the microphone under test is compared with the known sensitivity of a reference microphone. It is simple and can be done with commonly-available equipment and requires minor investment.
- c) The pistonphone works on the principle of a pair of similar opposing, reciprocating pistons actuated by a precision-machined cam disc with a sinusoidal profile. The profile of the cam disc is such that the pistons follow a sinusoidal movement at a frequency equal to four times the speed of rotation. This results in a corresponding sinusoidal variation in the effective volume of the closed coupler and, consequently, an acoustic signal within it.

The mechanical structure of the pistonphone makes this generated acoustic pressure (typically 114 dB @250 Hz) signal very reliable and stable. By careful control of the atmospheric pressure conditions and the calibration temperature, the calibration far exceeds the requirements for class LS calibrators. Absolute calibration accuracy has been determined to be within  $\pm 0.05$  dB at reference conditions for the pistonphone.

- At 250 Hz, the frequency response of most microphones is flat and will give a more accurate result.
- d) A sound calibrator provides a convenient method for microphone level calibration. While it does not offer the same precision as a pistonphone, it has the advantage of requiring no user-applied corrections, such as static-pressure adjustments. Most

sound calibrators operate at a single reference frequency of 1000 Hz, though some models offer additional frequencies.

- At 1000 Hz, weighting filters have 0 dB attenuation and will therefore not affect the calibration. In these cases, it might be an advantage to use a 1000 Hz calibration tone.

GRAS offers a sound calibrator that can calibrate microphones both using a 250 Hz and 1000 Hz reference signal at 94 or 114 dB.

A frequency-response calibration describes the response of the microphone over a range of frequencies. Frequency-response measurements can be presented in various ways, i.e., pressure response, free-field response, and diffuse-field response.

Generally, pressure response is determined by using an electrostatic actuator which simulates purely an oscillating pressure exerted on the microphone's diaphragm. Free-field and diffuse-field responses can then be arrived at by adding predetermined correction values to the measured actuator (pressure) response of the microphone.

Electrostatic actuators require no special acoustic laboratory facilities since background noise is not too critical a factor. An electrostatic actuator consists of an electrically conductive rigid plate mounted close to, and parallel with, the microphone's diaphragm. When an oscillating voltage is applied between the microphone's housing and the electrostatic actuator, an oscillating force will be exerted on the diaphragm. This oscillating force simulates an oscillating sound pressure, thus making it possible to determine the response of the microphone to pressure alone. This means that the frequency response of microphones can be measured under normal circumstances, not requiring special sound -insulated test chambers, as long as the background noise levels are reasonably low.

GRAS offers a comprehensive range of components for level and frequency calibration of microphone capsules and complete microphone sets, as well as fully integrated level and frequency calibration systems. In addition, GRAS provides audiometer calibration systems and tools for measuring phase matching between microphones.



## GRAS 42AC

### High Pressure Pistonphone



42AC is a precision sound source for calibrating microphones, sound level meters and other sound measuring equipment at high levels. It is battery-operated and produces a constant nominal sound pressure level of 134 dB re. 20  $\mu$ Pa (equivalent to 100 Pa) at 250 Hz, or 125.4 dB(A) re. 20  $\mu$ Pa. Each 42AC is within 0.1 dB of the nominal value and is delivered with an individual calibration chart and a barometer for Class 1 static pressure corrections. For Class 0 static pressure corrections, a precision barometer is required.

42AC can be used both for field checks of complete measurement systems as well as for laboratory calibrations of measurement microphones. It complies with the requirements of IEC 60942 (1988) Class 1. An adapter (GR0398) is included for use with hydrophone couplers.

Specifications	42AC	42AP
Sound pressure level	134 dB (re. 20 $\mu$ Pa) $\pm$ 0.1 dB	114 dB (re. 20 $\mu$ Pa) $\pm$ 0.08 dB
Frequency	250 Hz	250 Hz or 251.2 Hz
Accuracy	IEC 60942 (1988) Class 1	IEC 60942 (1988) Class 0, LS
Temperature range	-10°C to +55°C	-10°C to +55°C
Batteries	4 x AA alkaline (IEC LR 6)	4 x AA alkaline (IEC LR 6)
External power	-	6V DC 125mA
Weight	325 g	437 g

## GRAS 42AP

### Intelligent Pistonphone



42AP is a battery-operated precision sound source for calibrating microphones, sound level meters and other sound measuring equipment. It has built-in precision barometer and thermometer. Via its display and RS-232 interface, the user can read the actual corrected sound pressure level, as well as the calibration temperature and ambient static pressure.

It produces a constant nominal sound pressure level of 114 dB re. 20  $\mu$ Pa (equivalent to 10 Pa) at either 250 Hz or 251.2 Hz (true centre frequency of a 250 Hz, 1/3-octave band filter).

The actual sound pressure level, corrected for static ambient pressure, is shown on its display, which can also show the A-weighted sound pressure level after correcting it for using an A-weighting filter.

#### The display can be switched to show any of the following:

- Actual corrected sound pressure level in decibels
- Actual corrected sound pressure level in decibels, if measured with an A-weighting filter
- Static air pressure in hPa
- Calibration temperature in °C
- Calibration temperature in °F
- The pistonphone frequency can be programmed, via its RS-232 interface, to be either 250 Hz or 251.2 Hz
- 42AP is an extremely stable laboratory standard sound source, which can also be used for field calibrations—it retains its high accuracy even under hostile environmental conditions. It complies with all the requirements of IEC Standard 60942 (2003) LS
- An individual calibration chart is part of the delivery.

## GRAS 42AG

### Multifunction Sound Calibrator



The 42AG Multifunction Sound Calibrator is a portable, battery-operated precision microphone calibrator. The calibrator can be used directly on 1" microphones. Adapters for calibrating 1/2" (factory mounted), 1/4" and 1/8" microphones are included. It can produce a sinusoidal signal of 250 Hz or 1 kHz at 94 dB or 114 dB.

The calibration level is virtually independent of ambient conditions like temperature, atmospheric pressure and humidity within the specified range of operation. For documentation purposes, 42AG provides display of the environmental conditions: ambient air pressure, and temperature.

42AG comes with adapters for all standard microphone sizes from 1" down to 1/8".

Specifications	42AG
Sound pressure level	94 dB ( $\pm 0.2$ dB) or 114 dB ( $\pm 0.2$ dB)
Frequency	250 (251.19 $\pm$ 0.30 Hz) or 1 kHz (1000 $\pm$ 1 Hz)
Accuracy	IEC 60942 (1988) Class 1
Temperature range	-10°C to +50°C
Batteries	LR03 (AAA)
Weight	125 g

## GRAS 42AE

### Low Frequency Calibrator



42AE permits microphone calibration at frequencies down to 0.01 Hz for both front- and rear-vented microphones.

The two-port configuration allows the actual sound pressure in the coupler to be monitored by a reference microphone simultaneously with the microphone under test. The sound pressure can alternatively be monitored using the voltage output proportional to the pressure in the coupler. The built-in, DC-coupled power amplifier enables the calibrator to be used for swept-sine, broadband and step function investigations.

42AE is delivered with various types of adapters for calibrating 1/8" to 1" microphones and preamplifiers. A power supply is included.

Specifications	42AE
Sound Pressure Level	140 dB (re. 20 $\mu$ Pa)
Frequency	< 0.1 – 150 Hz
Signal Input (max)	0.7 Vrms
Calibration Signal	1 mV/Pa (140 dB max)
Weight	1.6 kg

## GRAS 14AA

### Electrostatic Actuator Amplifier



High voltage, high gain amplifier and voltage supply for driving electrostatic actuators. The high voltage output can also be used to drive standard microphones as sound sources. The 14AA can drive an electrostatic actuator with a 300 V peak-to-peak signal superimposed on 800 V DC.

Its wide frequency range makes it possible to determine the pressure frequency response of condenser microphones from 1 Hz to 200 kHz (note: care should be taken below 200 Hz because of the influence of pressure equalization in the rear volume of the microphone).

14AA can be connected directly to an external signal generator or the generator output of any standard signal analyzer.

Specifications	14AA
Input Signal (max)	1 Vrms
Gain	+ 40 dB
Output Signal (max)	300 V peak-to-peak
Actuator Voltage	800 V
Frequency Response	1 Hz – 200 kHz
Power Supply	110/130 V AC or 220/240 V AC
Weight	1.4 kg

## Calibration Stands



- AL0010** Calibration Stand
- AL0011** Calibration Stand for IEC 60318-1 Ear Simulator
- AL0017** Pistonphone Calibration Stand (not shown)
- AL0021** Microphone Set Calibration Stand (not shown)

The GRAS Calibration Stands provide convenient platforms for holding the microphones and accessories used for calibration. They ensure that microphones and accessories are mounted in exactly the same way every time you calibrate.

**AL0010** provides a platform for testing condenser microphones. It has a fixture for holding a 1/2" preamplifier securely in place as well as recesses and a column for safely parking electrostatic actuators and microphone protection grids when not in use. It can be set up for both 1/2" and 1" microphones.

**AL0011** provides a convenient platform for calibrating IEC 60318-1 Ear Simulators, e.g., RA0039. The stand and the adapters are designed for standardized frequency calibration using a transmitter setup with a microphone as sound source (not included) and the 14AA Electrostatic Actuator Amplifier for driving the setup.

## GRAS RA0014

### 1/2" Electrostatic Actuator



An electrostatic actuator for testing the frequency response of standard 1/2", 1/4" and 1/8" microphones. Adapters are included for testing 1/4" and 1/8" microphones. The RA0014 can be connected directly to the 14AA Electrostatic Actuator Amplifier.

## GRAS RA0014-S1

### 1/2" Electrostatic Actuator for 40AU-1



As RA0014, but with dimensions fitting 40AU-1.

## GRAS RA0015

### 1" Electrostatic Actuator



An electrostatic actuator for testing the frequency response of standard 1" microphones. The RA0015 can be connected directly to the 14AA Electrostatic Actuator Amplifier.

## GRAS RA4802 and RA4805



RA4802

**RA4802** Adapter for Frequency Calibration

**RA4805** Adapter Kit with RA4801 and RA4802



The RA4802 is an electrostatic actuator for frequency calibration, integrated in a stand with a mechanism for holding and locking the 48LA or 48LX-1 microphones during calibration. The RA4805 is a kit that includes the RA4801 and RA4802 adapters for sensitivity and frequency calibration of the 48LA and 48LX-1 UTP microphones.

## GRAS 51AB

### Intensity Calibrator



For calibrating the phase response of a pair of microphones used for measuring sound intensity, e.g., GRAS 40AI and GRAS 40BI. It includes a calibrated acoustic resistance to enable the computation of particle velocity and intensity levels.

Complies with IEC International Standard 61043.

#### Accessories included:

2 x 1/4" microphone adapters

Specifications	51AB
Input Connector	BNC socket
Maximum input signal	1 V RMS
Frequency Range	50 Hz – 6.3 kHz
Frequency-intensity index	>27 dB (nomin. mic. spacing 25 mm)
SPL difference between channels	<0.1 dB
Operating temperature range	+ 5°C to + 40°C
Dimensions	Height: 42.2 mm Width: 50.3 mm Depth: 60.0 mm
Weight	515 g

## GRAS Audiometer Calibration Systems



The GRAS Audiometer Calibration Systems are configured to meet the requirements of modern audio-meter calibration. They are easy and fast to set up and control, and can be upgraded as your calibration needs change. Two standard packages are available and several options can be added depending on the type and features of the audiometer and connected earphones.



*The GRAS 42AG Multifunction Sound Calibrator is also part of the delivery (not shown in the photo)*

### GRAS 90AA

#### Audiometer Calibration System



This system has been configured for the calibration technician on the move. It is portable and includes everything you need for calibrating supra- and circum-aural audiometric earphones like TDH-39 and HDA-200. The system includes a GRAS Audiometer Calibration Analyzer, two complete sets of standardized ear simulators on two coupler platforms, and a sound level calibrator and force gauge for verification of the system. All instrumentation is packed into a rugged suitcase that also allows space for options like free-field and insert-earphone calibration.

### GRAS 90AB

#### Basic Audiometer Calibration System



This system is configured for the stationary calibration lab and will also calibrate supra- and circum-aural audiometric earphones like TDH-39 and HDA-200. This configuration includes a GRAS Audiometer Calibration Analyzer, two complete sets of standardized ear simulators and a coupler platform.

Specifications	90AA & 90AB
Ear Simulators conform to:	ANSI 3.6 IEC 60318-1 & -2 & -3 & -4
Measured parameters:	Level, frequency and distortion (in one display)

## GRAS 90CA-S2

### Microphone Calibration System based on NI-PXI



*Computer for system control and monitor are part of the delivery (not shown in the photo)*



The GRAS 90CA-S2 Microphone Calibration System is a complete computer-controlled system for calibration of microphones and microphone sets. It provides you with a computer-controlled level and frequency-response calibration of measurement microphones and microphone sets. This highly automated process is convenient with its ready-to-use software and hardware, and auto-generated customizable documentation.

90CA-S2 provides accurate calibration hardware, easily changeable test conditions and a highly reproducible calibration method.

Calibration with the 90CA-S2 is in compliance with

- ANSI S1.10–1966 (R1976)
- IEC 61094-1
- IEC 61094-6

Additional software can be purchased for the calibration of preamplifiers.

Specifications	90CA-S2
Level Calibration:	250 Hz, 114 dB
Frequency Calibration:	20 Hz to 92 kHz*

\*Up to 200 kHz with additional hardware option

# Artificial Ears, Ear and Mouth Simulators, and KEMAR

The human ear is acoustically a complicated structure with volumes, channels and damping, resulting in a complex acoustical impedance. Also, at higher frequencies, the diffraction around the outer ear will change the acoustic field and result in a unique response at the inner ear.

In order to be able to compare and quantify measurements related to the human ear, a number of international standards and recommendations have defined some “ideal” or average ears. These can be simulated by more or less complicated mechanical and acoustical systems.

The IEC 60318-1 & 2 (60318) coupler is an example of a standardized human ear, having the same acoustic input impedance as an average human ear.

Another example is IEC 60318-4 (former 60711) Occluded-ear simulator for the measurement of earphones coupled to the ear by ear inserts.

Mouth simulators are sound sources for simulating the sound field around the human mouth at close quarters and are used for testing telephone mouthpieces as well as other microphones similarly used in vocal-communication networks. They are built around a loudspeaker and deliver sound signals at a “Mouth Reference Point” in accordance with International Standards IEEE 269, 661 and ITU-T Rec. P51.

The ear and mouth simulators can be incorporated into a wide range of measuring setups for testing mobile phones, communication systems, hearing aids, headphones, headsets, hearing protectors, audio systems, VR/AR glasses and headsets, etc.

The ear and mouth simulators can also be incorporated into a Head and Torso Simulator (HATS) like KEMAR, which lends more realism to in-situ anthropomorphic testing. KEMAR is a model of a human head and torso and has been extensively used for the last 45 years for studying the interaction between the human head and torso and sound fields.

GRAS offers ear and mouth simulators as standalone components, as well as in compact tabletop fixtures such as the 43AG. We also provide more comprehensive test fixtures, including the highly flexible and reconfigurable GRAS 45CC, and the 45CA, which is ideal for hearing protectors, sound isolation, and ANC measurements thanks to its high self-insertion loss. Finally, GRAS offers realistic, human-like test fixtures such as KEMAR and the 45CB.



## GRAS 43AA

Ear Simulator Kit According to IEC 60318-1



43AA is a complete test jig for acoustical measurements on telephone handsets and earphones in accordance with:

- IEC 60318-1 (60318) Electroacoustics—Simulators of human head and ear—Part 1: Ear simulator for the calibration of supra-aural and circumaural earphones,
- ITU-T Recommendation P.57 (08/96) Series P: Telephone transmission quality, Objective measuring apparatus: Artificial ears.

43AA also complies with IEC 60318-2 (1999) (withdrawn and now incorporated into 60318-1).

### Included:

- RA0039 IEC 60318-1 (60318) Ear Simulator
- 40AG 1/2" Pressure Microphone
- 26AC 1/4" Preamp
- Mounting plate for circum-aural headphones
- The RA0052 Test Jig has an adjustable spring-loaded arm to exert a variable force on the test object.

## GRAS 43AB

1/2" 2cc Coupler Kit According to IEC 60318-5



43AB is a complete test jig for acoustical measurements on hearing aids in accordance with IEC 60318-5 (60126) and ANSI S3.7-1995 on insert type hearing aids in accordance with:

- IEC 60318-5 (60126) IEC reference coupler for the measurement of hearing aids using earphones coupled to the ear by means of ear inserts.
- ANSI S3.7-1995 American National Standard for Coupler Calibration of Earphones.

### Included:

- RA0038 IEC 60318-5 (60126) 2cc Coupler
- 40AG 1/2" Pressure Microphone
- 26AC 1/4" Preamp
- The RA0052 Test Jig has an adjustable spring-loaded arm to exert a variable force on the test object
- Studs and moulds for BTE and ITE instruments.

## 43AA Variants

**43AA-S2** Ear Simulator Kit According to IEC 60318-1, CCP, IEEE 1451.4 TEDS v. 1.0 compliant—40AO Pre-polarized Pressure Microphone included.

**43AA-S3** Ear Simulator Kit According to IEC 60318-1, LEMO, as 43AA, but with 26AB Preamp.

Specifications	43AA	43AB
Standards	IEC 60318-1 ITU-T Rec. P.57	IEC 60318-5 ANSI S3.7
Dynamic Range (ext. pol. mic.) (prepol. mic.)	25 dB(A) – 164 dB 25 dB(A) – 153 dB	25 dB(A) – 164 dB
Effective Volume	-	2 cc
Weight	1650 g	1550 g

## GRAS 43AC

### Ear Simulator Kit According to IEC 60318-4



43AC is a complete test jig for acoustical measurements on earphones coupled to the ear by inserts such as tubes and ear moulds in accordance with:

- IEC 60318-4 (former 60711) Occluded-ear simulator for the measurement of earphones coupled to the ear by ear inserts.
- ITU-T Recommendations P.57 (08/96) Series P: Telephone transmission quality, Objective measuring apparatus: Artificial ears.

#### Included:

- RA0045 IEC 60318-4 (former 60711) Ear Simulator
- 40AG 1/2" Pressure Microphone
- 26AC 1/4" Preamp
- The RA0052 Test Jig has an adjustable spring-loaded arm to exert a variable force on the test object.

## GRAS 43AF

### 1" 6cc Coupler Kit According to IEC 60318-3



43AF is a complete test jig for acoustically testing telephone handsets and earphones in accordance with ANSI S3.7 – 1995 and IEC 60318-3.

#### Included:

- RA0075 NBS 9-A 6cc Coupler
- RA0076 Thread Adapter
- 40EN 1" Pressure Microphone (in WE 640AA configuration)
- 26AC 1/4" Preamp
- The RA0052 Test Jig has an adjustable spring-loaded arm to exert a variable force on the test object.

## 43AC Variants

**43AC-S1** Ear Simulator Kit According to IEC 60318-4, CCP. For more info about the included RA0045-S1, see page 76.

**43AC-S4** High-Frequency Ear Simulator Kit LEMO. For more info about the included RA0401, see page 76.

**43AC-S5** High-Frequency Ear Simulator Kit CCP. For more info about the included RA0402, see page 76

**43AC-S6** Hi-Res Ear Simulator Kit, LEMO. For more info about the included RA0403, see page 77.

**43AC-S7** Hi-Res Ear Simulator Kit, CCP. For more info about the included RA0404, see page 77.

Specifications	43AC	43AF
Standards	IEC 60318-4, ITU-T Rec. P.57	IEC 60318-3, ANSI S3.7
Performance data	RA0045, RA0045-S1 } specs. on RA0401, RA0402 } page 76 RA0403, RA0404	25 dB(A) – 160 dB
Effective Volume	1260 mm <sup>3</sup>	6cc
Weight	1650 g	1550 g

## GRAS 43AG

### Ear & Cheek Simulator Kit IEC 60318-4 & 7



43AG is a table top test device for measurements on earphones of various types. It simulates the ear and cheek of a human head as well as approximates the acoustic impedance of an average human ear. It can be used to verify frequency response, distortion, isolation and leakage. Its versatility means that it can be used for testing of both concha and insert types earphones. It can also be used for headphone and headset testing, both circum-aural and supra-aural types. Also, all common types of hearing-aids and telephone handset can be tested with 43AG.

The following configurations are available:

#### 43AG Configurations

- 43AG-1** Ear and Cheek Simulator LEMO is configured with an RA0045 Externally Polarized Ear Simulator According to IEC 60318-4 and a large KEMAR Right Pinna 55 Shore 00.
- 43AG-2** Ear and Cheek Simulator CCP is configured with a RA0045-S1 Prepolarized Ear Simulator According to IEC 60318-4 and a large KEMAR Right Pinna 55 Shore 00.
- 43AG-3** Ear and Cheek Simulator w Anthropometric Pinna LEMO is configured with an RA0045 Externally Polarized Ear Simulator According to IEC 60318-4 and a KB5000 Large KEMAR Right Anthropometric Pinna 35 Shore 00.
- 43AG-4** Ear and Cheek Simulator w Anthropometric Pinna CCP is configured with a RA0045-S1 Prepolarized Ear Simulator According to IEC 60318-4 and a KB5000 Large KEMAR Right Anthropometric Pinna 35 Shore 00.
- 43AG-5** Ear and Cheek Simulator, Low-noise is configured with a 43BB low-noise ear simulator system and a large KEMAR Right Anthropometric Pinna 35 Shore 00.
- 43AG-6** Ear and Cheek Simulator, High-Frequency, LEMO is configured with an RA0401 Externally Polarized High-Frequency Ear Simulator and a KB5000 Large KEMAR Right Anthropometric Pinna 35 Shore 00.
- 43AG-7** Ear and Cheek Simulator, High-Frequency CCP is configured with an RA0402 Prepolarized High-Frequency Ear Simulator and a KB5000 Large KEMAR Right Anthropometric Pinna 35 Shore 00.
- 43AG-8** Ear and Cheek Simulator, Hi-Res, LEMO is configured with an RA0403 Externally Polarized Hi-Res Ear Simulator and a KB5000 Large KEMAR Right Anthropometric Pinna 35 Shore 00.
- 43AG-9** Ear and Cheek Simulator, Hi-Res, CCP is configured with an RA0404 Prepolarized Hi-Res Ear Simulator and a KB5000 Large KEMAR Right Anthropometric Pinna 35 Shore 00.

#### Specifications

For specifications for the Ear Simulators, see page 76 and 77.

For specifications for 43BB, page 73

For more information about the Pinnae, see page 114.

## GRAS 43BA

### 1/4" 0.4cc High-frequency Coupler Kit



43BA is a high frequency 1/4" 0.4cc coupler for test of hearing aids at frequencies up to 16 kHz and fulfils IEC60318-8. It is a complete kit with a 1/4" pressure microphone, a 1/4" preamplifier and the same adapters known from the reference 2cc coupler. It is designed for repetitive use and is equally suited for research, quality assurance and production test applications.

The 43BA coupler kit is designed to facilitate the measurement needs described in the IEC TS 62886:2016 "Method for measuring electroacoustic performance up to 16 kHz" and meets the need for an accurate and repeatable measurement method that can be used by designers of hearing aids and hearing aids receivers, and by fitters of hearing aids.



Three versions of the 0.4cc coupler kit are available:

### 43BA Coupler Kits

- 43BA-1** 1/4" 0.4cc High Frequency Coupler Kit Includes 40BP 1/4" Ext. Polarized Pressure Microphone, 26AS 1/4" Standard Preamplifier with 3 m Integrated Cable, Very Short and RA0252 1/4" 0.4cc High frequency Coupler as well as cable and adapters.
- 43BA-2** 1/4" 0.4cc CCP High Frequency Coupler Kit Includes 40BD 1/4" prepolarized Pressure Microphone, 26CS 1/4" CCP Standard Preamplifier with Microdot Connector, Very Short and RA0252 1/4" 0.4cc High frequency Coupler as well as cable and adapters.
- 43BA-3** 1/4" 0.4cc CCP High Frequency Coupler Kit, High Sensitivity Includes a special 1/4" prepolarized high-sensitivity microphone, 26CS 1/4" CCP Standard Preamplifier with Microdot Connector, Very Short and RA0252 1/4" 0.4cc High frequency Coupler as well as cable and adapters.

## GRAS 43BB

### Low-noise Ear Simulator System



43BB is a low-noise, high-sensitive ear simulator system for measurements of sound pressure levels close to or below the threshold of human hearing.

It has a very low noise floor—below 10.5 dB(A)—and can measure sound levels below or close to the threshold of human hearing. For comparison, a standard IEC 60318-4 (711) ear simulator with a 40AG 1/2" microphone has its noise floor at 24.2 dB(A).

It consists of the well known standardized IEC 60318-4 ear simulator and the 40HT Low-noise Microphone System.

*43BB-1 is a variant designed for mounting in low-noise configurations of KEMAR HATS like 43BB-11/12 and 45BC-11/12. 43BB-3 is identical to the 43BB except that it uses an 8-degree angled adapter for the preamplifier and therefore can be used inside test fixtures like the GRAS 45CA. 43BB-4 is identical to the 43BB except that it uses an 8-degree angled adapter for the preamplifier with a built-in short 40 cm cable and can be used inside the GRAS 45CB.*



Specifications	43BB
Connector	7-pin LEMO with 3-m cable
Dynamic range	10.5 dB(A) – 113 dB
Coupler volume	1260 mm <sup>3</sup>

## GRAS RA0038

### 1/2" 2cc Coupler IEC 60318-5



An IEC 60318-5 (60126) 2cc coupler which complies with the requirements of:

- IEC 60318-5 (60126) IEC reference coupler for the measurement of hearing aids using earphones coupled to the ear by means of ear inserts.
- ANSI S3.7-1995 American National Standard for Coupler Calibration of Earphones.

It is used with a 40AG 1/2" microphone and a 26AS preamplifier, which is a 1/4" very short preamplifier with 3 m integrated cable supplied with an adapter for 1/2" microphones. RA0038 is also part of the 43AB 2cc Coupler Kit.

## GRAS RA0113

### 1" 2cc Coupler IEC 60318-5



RA0113 is a 2cc IEC 60318-5 (60126) coupler which uses a 1" microphone, like 40EN and a 1/2" preamplifier like 26AK supplied with e.g., RA0073 Adapter.

The microphone, without its grid, screws into the base of RA0113. In all other respects, this coupler is equivalent to RA0038. It complies with the following international and national requirements for testing insert type hearing aids:

- IEC 60318-5 (60126) IEC reference Coupler for the measurement of hearing aids using earphones coupled to the ear by means of ear inserts.
- ANSI S3.7-1995 American National Standard for Coupler Calibration of Earphones.

## GRAS RA0075

### NBS 9-A 6cc Coupler



RA0075 is for testing earphones according to ANSI 3.7 - 1995 and IEC 60318-3. It can be used with a 1" pressure microphone like 40EN, a 1/2" preamplifier like 26AK and various adapters, e.g., RA0073.

## GRAS RA0039

### Ear Simulator IEC 60318-1



RA0039 is an IEC 60318-1 (60318) Ear Simulator with an input impedance closely resembling that of an average human ear. When coupled to a sound source, its impedance will load the sound source similar to the loading caused by the human ear. It complies with the requirements of:

- IEC 60318-1 (60318) Electroacoustics—Simulators of human head and ear—Part 1: Ear simulator for the calibration of supra-aural earphones, 1998-07.
- ITU-T Recommendation P.57 (08/96) Series P: Telephone transmission quality, Objective measuring apparatus: Artificial ears.

RA0039 is also part of the 43AA and 43AD Ear Simulator kits.

## GRAS RA0252

### 1/4" 0.4cc High-frequency Coupler



The coupler used in the 43BA kits is available separately i.e., without microphone, ear mould and tube adapters.

Specifications	RA0038	RA0075	RA0252	RA0113	RA0039
Standards	IEC 60318-5 (60126) ANSI S3.7-1995	ANSI S3.7-1995, Coupler calibration of earphones	IEC 60318-8	IEC 60318-5 ANSI S3.7 (1995)	IEC 60318-1 (60318) / ITU-T Rec. P.57 (08/96)
Effective Volume	2 cc	6 cc	0.4 cc	2 cc	-

## GRAS RA0056

### Low-leak Pinna Simulator



A low-leak pinna (outer ear) simulator for use with the RA0045 Ear Simulator to simulate a complete ear for testing telephones and loudspeakers. The RA0056 meets the specifications in the ITU-T Recommendation P.57 (08/96) "Series P: Telephone transmission quality, Objective measuring apparatus: Artificial ears".

## GRAS RA0057

### High-leak Pinna Simulator



A high-leak pinna (outer ear) simulator for use with the RA0045 Ear Simulator to simulate a complete ear for testing telephones and loudspeakers. The RA0057 meets the specifications in the ITU-T Recommendation P.57 (08/96) "Series P: Telephone transmission quality, Objective measuring apparatus: Artificial ears".

## IEC 60318-4 Ear Simulators

**RA0045** Externally Polarized Ear Simulator IEC 60318-4

**RA0045-S1** Prepolarized Ear Simulator IEC 60318-4



**RA0045** is an IEC 60318-4 (former 60711) Ear Simulator for making acoustic measurements on earphones coupled to the human ear by ear inserts such as tubes, ear moulds or ear tips in accordance with:

- IEC 60318-4 (former 60711) Occluded-ear simulator for the measurement of earphones coupled to the ear by ear inserts.
- ITU-T Recommendations P.57 (08/96) Series P: Telephone transmission quality, Objective measuring apparatus: Artificial ears.

It is delivered with a built-in 40AG 1/2" microphone and an individual calibration chart for the coupler-microphone combination. Can be used with either of the RA0056 and RA0057 Pinna Simulators to simulate a complete ear for testing telephones and loudspeakers.



**RA0045-S1** is similar to RA0045 but is delivered with a built-in prepolarized microphone GRAS 40A0 for use with CCP preamplifiers.

### More RA0045 Variants

**RA0045-S4** High-sensitivity, 40AP Ext. Pol. Microphone

**RA0045-S5** High-pressure, 40BP Ext. Pol. Microphone

**RA0045-S6** High-sensitivity, 40AD Prepol. Microphone

Specifications for these RA0045 variants can be found at [www.grasacoustics.com](http://www.grasacoustics.com)

## IEC 60318-4 Ear Simulators, High-Frequency

**RA0401** Externally Polarized High-Frequency Ear Simulator IEC 60318-4

**RA0402** Prepolarized High-Frequency Ear Simulator IEC 60318-4



**RA0401** is a high-frequency version of the standardized 60318-4 ear simulator (RA0045), which has gained wide acceptance as the preferred tool for measurements with simulation of the acoustic load presented by the human ear. Below 10 kHz, the standardized ear simulator does a good job. However, above 10 kHz, the steep resonance at 13.5 kHz dominates. In RA0401 this resonance is damped and the useful frequency range is extended to 20 kHz.

RA0401 complies with IEC60318-4 and is fully backward compatible as its acoustic transfer impedance is within the tolerance band specified by IEC60318-4. From 10 to 20 kHz the transfer impedance is within  $\pm 2.2$  dB, resulting in improved repeatability. Also, realistic THD measurements are now possible.



It is measured and calibrated according to the ITU-T Recommendation P.57 and delivered with a calibration chart specifying its sensitivity and frequency response.



**RA0402** is similar to RA0401 but has a built-in prepolarized microphone for use with CCP preamplifiers.

Specifications	RA0045/RA0045-S1	RA0401/RA0402	RA0403/RA0404
Standards	IEC 60318-4 (former 60711) ITU-T Rec. P.57 (08/96)	IEC 60318-4 (former 60711) ITU-T Rec. P.57 (08/96)	IEC 60318-4 (former 60711) compatible ITU-T Rec. P.57 (08/96)
Dynamic Range	25 dB(A) – 164 dB/25 dB(A) – 150 dB	25 dB(A) – 164 dB/25 dB(A) – 150 dB	44 dB(A) – 169 dB/44dB(A) – 166 dB
Effective Volume	1260 @ 500 Hz	1260 @ 500 Hz	1260 @ 500 Hz
Resonant Frequency	13.5 kHz $\pm$ 1 kHz	13.5 kHz $\pm$ 1 kHz	13.5 kHz $\pm$ 1 kHz
Height	36.5 mm	36.5 mm	36.5 mm
Diameter	23.8 mm	23.8 mm	23.8 mm
Weight	71 g	74 g	74 g

## IEC 60318-4 Ear Simulators, Hi-Res

**RA0403** Externally Polarized Hi-Res Ear Simulator

**RA0404** Prepolarized Hi-Res Ear Simulator



**RA0403** is a Hi-Res version of the well-known standardized 60318-4 ear simulator (RA0045), which has gained wide acceptance as the preferred tool for measurements with simulation of the acoustic load presented by the human ear. Below 10 kHz, the standardized ear simulator does a good job. However, above 10 kHz, the steep resonance at 13.5 kHz dominates. In RA0403 this resonance is damped. This, in combination with the use of a 1/4" microphone, extends the useful frequency range to 50 kHz.

RA0403 is compatible with IEC60318-4 and is fully backward compatible as its acoustic transfer impedance is within the tolerance band specified by IEC60318-4. From 10 to 20 kHz the transfer impedance is within  $\pm 2.2$  dB, from 20 kHz to 50 kHz it is within  $\pm 3.2$  dB, resulting in improved repeatability. Also, realistic THD measurements are now possible in the full audible frequency range.

It is measured and calibrated according to the ITU-T Recommendation P.57 and delivered with a calibration chart specifying its sensitivity and frequency response.



**RA0404** is similar to RA0403 but is delivered with a built-in prepolarized microphone for use with CCP preamplifiers.

*Specifications on the previous page.*

## Evolution of the IEC 60318-4 (711) Ear Simulator

For more than three decades, the IEC 60318-4 ear simulator has been the recognized industry standard for testing audio transducers. However, its undamped resonance at 13.5 kHz makes it difficult to use for high-frequency testing above 10 kHz. Therefore, GRAS has introduced two improved variants of the IEC 60318-4 ear simulator. They retain a firm footing in the standard but improve the ability to measure at high frequencies.

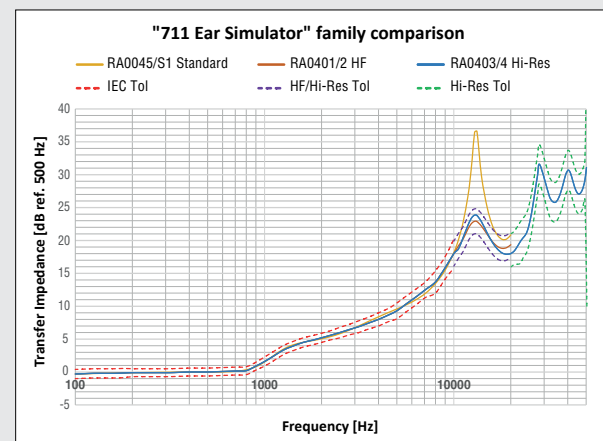

### The Standard IEC 60318-4 (711) Ear Simulator (GRAS RA0045/-S1)

The design that started it all, described on the IEC 60318-4 standard. It is captured in the GRAS RA0045 and GRAS RA0045-S1 ear simulators. They have a step half-wave resonance at 13.5 kHz which effectively limits its usefulness to below at least 10 kHz. It uses a 1/2" pressure microphone.

### The High-Frequency Ear Simulator (GRAS RA0401/02)

The GRAS RA0401 and RA0402 has a damping system that attenuates the half-wave resonance at 13.5 kHz and thus extends the useful frequency range up to 20 kHz. It also adds tolerances in its transfer impedance curve above 10 kHz and up to 20 kHz. These tolerances are not present in the IEC standard. The addition of this damping system and tolerance make the RA0401/2 ear simulator, the new normal for testing. It also uses a 1/2" pressure microphone.

### The Hi-Res Ear Simulator (GRAS RA0403/04)

The GRAS RA0403 and RA0404 also has a damping system that attenuates the length-related resonances above 10 kHz, but the use of a 1/4" microphone extends the useful frequency range to 50 kHz and beyond. Tolerances to the transfer impedance curve are also now present up to 50 kHz. This is the preferred ear simulator option for Hi-Res certification, tests up to 50 kHz or when very high sound pressure levels need to be measured.

## GRAS 45BB

### 45BC KEMAR Head & Torso



KEMAR is a head and torso simulator which is factory configured for hearing aid tests, ear- and headphone tests or sound quality recordings. Introduced in 1972 by Knowles Electronics and acquired by GRAS in 2005, it is the origin of all other head and torso simulators and thus the industry standard for in situ anthropomorphic testing of all kinds of hearing instruments and head- and earphones.

KEMAR is available with and without mouth simulator. It meets the requirements of ANSI S3.36 and IEC 60318-7 and can be configured with more sizes of standardized pinna simulators, the IEC 60318-4 Ear Simulators or various 1/2" and 1/4" pressure microphones for binaural recordings. KEMAR accommodates for LEMO as well as CCP preamplifiers which are all electrically accessible from the connector panel on the back. Additionally, all CCP configurations are IEEE 1451.4 TEDS v. 1.0 compliant.

The preconfigured KEMAR models include ear simulators, microphones, preamplifiers and pinnae for specific applications. They are delivered fully assembled and tested in one box.

*A number of rubber pinnae (small and large, soft and hard, anthropometric and wide aperture) are available. 3D-simulation models (step files) of KEMAR with pinnae are also available. See page 114.*



## KEMAR Configurations

- 45BB-1** KEMAR Head & Torso for Hearing Aid Test, 1-Ch LEMO
- 45BB-2** KEMAR Head & Torso for Hearing Aid Test, 1-Ch CCP
- 45BB-3** KEMAR Head & Torso for Sound Quality Recording, 2-Ch LEMO
- 45BB-4** KEMAR Head & Torso for Sound Quality Recording, 2-Ch CCP
- 45BB-5** KEMAR Head & Torso for Ear- and Headphone Test, 2-Ch LEMO
- 45BB-6** KEMAR Head & Torso for Ear- and Headphone Test, 2-Ch CCP
- 45BB-7** KEMAR Head & Torso for Test of Binaural Hearing Aid, 2-Ch LEMO
- 45BB-8** KEMAR Head & Torso for Test of Binaural Hearing Aid, 2-Ch CCP
- 45BB-9** KEMAR with Anthropometric Pinnae for Ear- and Headphone Test, 2-Ch LEMO
- 45BB-10** KEMAR with Anthropometric Pinnae for Ear- and Headphone Test, 2-Ch CCP
- 45BB-11** KEMAR with Anthropometric Pinnae for Low-noise Ear- and Headphone Test, 1-Ch LEMO
- 45BB-12** KEMAR with Anthropometric Pinnae for Low-noise Ear- and Headphone Test, 2-Ch LEMO
- 45BB-13** KEMAR for High-Frequency Test of Ear- and Headphones, 2-Ch LEMO
- 45BB-14** KEMAR for High-Frequency Test of Ear- and Headphones, 2-Ch CCP
- 45BB-15** KEMAR for Hi-Res Test of Ear- and Headphones, 2-Ch LEMO
- 45BB-16** KEMAR for Hi-Res Test of Ear- and Headphones, 2-Ch CCP

## GRAS 45BC

### 45BC KEMAR Head & Torso with Mouth Simulator



The GRAS KEMAR 45BC is a variant of the renowned GRAS Head & Torso Simulator, sharing the core characteristics of the 45BB but incorporating an integrated mouth simulator.

The built-in mouth simulator in the 45BC KEMAR is designed in accordance with the ITU-T P.51 Artificial Mouth standard. It can reproduce reference signals such as speech, accurately emulating the acoustic conditions of a human talker. This capability makes it ideal for evaluating communication devices including mobile phones, handsets, headsets, and similar products.

The mouth simulator can operate in active mode using the built-in audio amplifier housed within the KEMAR torso, or in passive mode with an external amplifier.

Calibration of the mouth is performed using the supplied neck-mounted microphone holder and a 1/4" measurement microphone.

As with the 45BB, the 45BC KEMAR is available in multiple configurations featuring different ear simulators, pinnae, and microphone options.

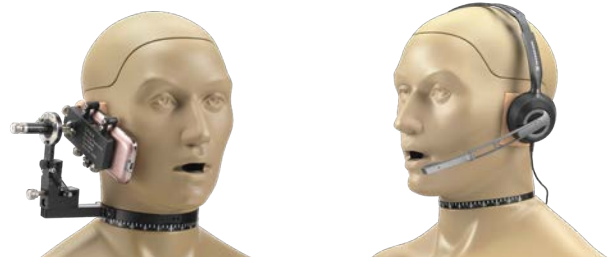

## KEMAR Configurations

- 45BC-1** KEMAR Head & Torso with Mouth Simulator for Headset Test, 2-Ch LEMO
- 45BC-2** KEMAR Head & Torso with Mouth Simulator for Headset Test, 2-Ch CCP
- 45BC-9** KEMAR with Mouth Simulator and Anthropometric Pinnae for Headset Test, 2-Ch LEMO
- 45BC-10** KEMAR with Mouth Simulator and Anthropometric Pinnae for Headset Test, 2-Ch CCP
- 45BC-11** KEMAR with Mouth Simulator and Anthropometric Pinnae for Low-noise Headset Test, 1-Ch LEMO
- 45BC-12** KEMAR with Mouth Simulator and Anthropometric Pinnae for Low-noise Headset Test, 2-Ch LEMO
- 45BC-13** KEMAR with Mouth Simulator for High-Frequency Headset Test, 2-Ch LEMO
- 45BC-14** KEMAR with Mouth Simulator for High-Frequency Headset Test, 2-Ch CCP
- 45BC-15** KEMAR with Mouth Simulator for Hi-Res Test of Headsets, 2-Ch LEMO
- 45BC-16** KEMAR with Mouth Simulator for Hi-Res Test of Headsets, 2-Ch CCP

## GRAS 45CA

### Headphone/Hearing-protector Test Fixture



45CA's robust design makes it ideally suited for binaural testing of active and passive earplugs, as well as circumaural hearing protectors. It is primarily intended for testing the performance of hearing-protection devices but can also be used for testing earphones and headphones. It is fitted with either microphones or ear simulators, depending on the device to test and the standard to comply with. Compliance with ISO 4869-3, IEC 60318-1 and IEC 60318-4 assures technicians, decision makers, and authorities of repeatability and transparent data when developing and verifying hearing protectors. Additionally, all CCP configurations (-2, -4, -6, -8, -10, and -12) are IEEE 1451.4 TEDS v. 1.0 compliant.

The pinnae for 45CA are basically the same as the standard KEMAR pinnae, but rounded to fit the large 45CA base plate. This large base plate reduces or eliminates the risk of leakage. 45CA includes two plugs for measuring the acoustic isolation in a closed ear.

The most common configurations can be ordered fully assembled, calibrated. They are listed below.

Specifications	4CA
ISO standard	ISO 4869-3 (45CA-1 & 2)
ITU-T Recommendations	P.380
IEC standard	60318-1 (45CA-3 & 4) 60318-4 (45CA-5 to 45CA-10 & 45CA-13) 60318-4 compatible (45CA-11 & 12)
Self Insertion Loss, measured with closed ear simulators (45CA-1 and 45CA-2)	
80-250 Hz	>50 dB
350 – 4000 Hz	>65 dB
5000 – 20.000 Hz	>55 dB
Weight	11.6 kg
<i>For more specifications, visit <a href="http://www.grasacoustics.com">www.grasacoustics.com</a></i>	



- Supra- and circumaural headphones
- On ear
- Insert-type earphones

The 45CA can be configured with silicone rubber pinnae featuring either straight or anthropometric ear canals, enabling realistic testing and proper fit evaluation of on-ear, in-ear, and headset devices. Acoustic loading is provided by a “711-style” ear simulator, ensuring standardized and repeatable measurement conditions.

- Supra- and circumaural headphones
- On ear

The 45CA is equipped with an IEC 60318-1 ear simulator and is ideal for testing on-ear and around-the-ear headphones under the acoustic loading conditions provided by the simulator. Its design is simplified by the absence of pinnae, offering a more streamlined setup while maintaining standardized acoustic performance.

- Hearing protection

This 45CA version is built in accordance with ISO 4869-3 and is used for self-insertion loss testing of hearing protectors such as ear muffs.

## 45CA Configurations

- 45CA-1** Headphone/Hearing-Protector Test Fixture, ISO 4869-3 1" Mic. LEMO—for test of ear muffs
- 45CA-2** Headphone/Hearing-Protector Test Fixture, ISO 4869-3 1/2" Mic. CCP—for test of ear muffs
- 45CA-3** Headphone/Hearing-Protector Test Fixture, IEC 60318-1 LEMO—for test of ear muffs and headphones
- 45CA-4** Headphone/Hearing-Protector Test Fixture, IEC 60318-1 CCP—for test of ear muffs and headphones
- 45CA-5** Headphone/Hearing-Protector Test Fixture, IEC 60318-4 LEMO—test of ear muffs, ear plugs, headphones, ear phones
- 45CA-6** Headphone/Hearing-Protector Test Fixture, IEC 60318-4 CCP—test of ear muffs, ear plugs, headphones, ear phones
- 45CA-7** Headphone/Hearing-Protector Test Fixture, IEC 60318-4 LEMO, with Anthropometric Pinnae—for test of ear muffs, ear plugs, headphones and ear phones
- 45CA-8** Headphone/Hearing-Protector Test Fixture, IEC 60318-4 CCP, with Anthropometric Pinnae—for test of ear muffs, ear plugs, headphones and ear phones
- 45CA-9** Headphone/Hearing-Protector Test Fixture, IEC 60318-4 LEMO, High-Frequency with Anthropometric Pinnae—for test of headphones and ear phones up to 20 kHz
- 45CA-10** Headphone/Hearing-Protector Test Fixture, IEC 60318-4 CCP, High-Frequency with Anthropometric Pinnae—for test of headphones and ear phones up to 20 kHz
- 45CA-11** Headphone/Hearing-Protector Test Fixture, IEC 60318-4 LEMO, Hi-Res, with Anthropometric Pinnae—for test of headphones and ear phones up to 50 kHz
- 45CA-12** Headphone/Hearing-Protector Test Fixture, IEC 60318-4 CCP, Hi-Res, with Anthropometric Pinnae—for test of headphones and ear phones up to 50 kHz
- 45CA-13** Headphone/Hearing-Protector Test Fixture, IEC 60318-4 compliant, Low Noise Ear Simulator System with Anthropometric Pinnae—especially suited for ANC headphones and ear phones testing

## GRAS 45CB

### Acoustic Test Fixture According to ANSI S12.42



45CB is designed for standardized, binaural testing of passive and active earmuffs and earplugs. Besides a robust design made for field testing and high sound pressure levels (blasts), it has a very high self-insertion loss, body temperature regulated ear-canals with silicone lining and a huge pinna surround—all to provide the most realistic and repeatable fit.

45CB directly handles sound pressure levels up to 169 dB and, indirectly (using comparison methods), levels up to 190 dB. It has a self insertion-loss better than 65 dB.

The modified IEC 60318-4 ear simulator with 1/4" microphone extends the frequency range as required by the standard. The 14-mm long ear canal extension is designed to let you also test all types of ear plugs.

The silicone-rubber lining of the extension enables leakage-free mounting of both foam plugs and customized molded types. The silicone-rubber lining of the plates ensures leakage-free mounting, as well as high repeatability and reliability.

Also available are 45CB-S1 for lower sound pressure levels and 45CB-S2 for higher sound pressure levels.

The 45CB is a unique GRAS solution designed for testing hearing protection systems and communication devices in both indoor and outdoor environments. Its ears and ear canals incorporate an integrated heating system that maintains a stable temperature, improving the reliability and accuracy of test results by replicating the thermal conditions of a real human ear.

The 45CB is also deployed inside battlefield vehicles to evaluate the performance of hearing protection systems, voice clarity, and other communication-related factors.

The head geometry supports realistic helmet placement, and the rugged construction provides the durability required for demanding field-testing scenarios.

The 45CB is also widely used in headphone testing applications for self-insertion loss measurements, particularly when realistic head geometry is required.

The 45CB is available in several configurations:

- 45CB-S1: Acoustic Test Fixture compliant with ANSI S12.42, high-sensitivity version
- 45CB-S2: Acoustic Test Fixture compliant with ANSI S12.42, for high-SPL testing
- 45CB-S4: Acoustic Test Fixture compliant with ANSI S12.42, low-noise version



Specifications	45CB
Sensitivity	1.6 mV
Dynamic range	50 dB(A) – 169 dB
Self insertion Loss	100 Hz – 8 kHz: > 74 dB / 80 Hz – 12.5 kHz: > 65 dB
Standard	ANSI S12.42
Connector	7-pin LEMO
Weight	14.75 kg

## GRAS 67SB

### Blast Probe Microphone



The 67SB Blast Probe is designed as a reference microphone for impulse measurements according to the ANSI S12.42 standard.

The 1/8" reference microphone inside it is ideally suited for capturing impulsive signals with a very fine time resolution. This microphone has an upper limit of 174 dB in the dynamic range.

An adapter is included with the 67SB, so you can perform a verification of the microphone before each use.

67SB is provided with a 1/4" threaded hole for mounting directly on a tripod, e.g., AL0006.

Specifications	67SB
Sensitivity	1 mV
Dynamic range	10 – 20 kHz
Self insertion Loss	52 dB(A) – 174 dB
Standard	ANSI S12.42
Connector	7-pin LEMO
Weight	650 g

## GRAS 45CC

### Headphone Test Fixture



45CC is a flexible platform for dual-channel testing of headphones and headsets. It is available in a variety of configurations: IEC 60318-1 or IEC 60318-4 ear simulators; baseplates, artificial ear simulators or human-like pinnae; and all are IEEE 1451.4 TEDS v. 1.0 compliant. An optional ITU-T P.51 mouth simulators (GRAS 44AA-1 or 44AB-1) extends testing to headsets. It can be adjusted very precisely to support different headphone/headset designs and sizes for high accuracy and repeatability. It is well suited for research and development, quality control and production line testing.



### 45CC Configuration

- 45CC-1** Headphone Test Fixture with Externally Polarized 1/2" Microphones
- 45CC-2** Headphone Test Fixture with Prepolarized 1/2" Microphones
- 45CC-3** Headphone Test Fixture with IEC 60318-1 Ear Simulators and Ext. Polarized 1/2" Microphones
- 45CC-4** Headphone Test Fixture with IEC 60318-1 Ear Simulators and Prepolarized 1/2" Microphones
- 45CC-9** Headphone Test Fixture with Externally Polarized 1/4" Microphones
- 45CC-10** Headphone Test Fixture with Prepolarized 1/4" Microphones
- 45CC-14** Test Fixture with IEC 60318-4 Ear Simulators, Anthropometric Pinnae and Ext. Polarized Microphones
- 45CC-15** Test Fixture with IEC 60318-4 Ear Simulators, Anthropometric Pinnae and Prepolarized Microphones
- 45CC-16** Test Fixture with High-frequency Ear Simulators, Anthropometric Pinnae and Ext. Polarized Microphones
- 45CC-17** Test Fixture with High-frequency Ear Simulators, Anthropometric Pinnae and Prepolarized Microphones
- 45CC-18** Test Fixture with High-resolution Ear Simulators, Anthropometric Pinnae and Ext. Polarized Microphones
- 45CC-19** Test Fixture with High-resolution Ear Simulators, Anthropometric Pinnae and Prepolarized Microphones

Specifications	4CC	
IEC 61094-4 1/2" WS2P Microphones in the Ear Plate Plane (45CC-1 - -4)	Microphone Assembly 69CC-1	Microphone Assembly 69CC-2
Frequency response	3.15 Hz – 20 kHz	
Dynamic range	25 dB(A) – 164 dB	25 dB(A) – 150 dB
IEC 61094-4 1/4" WS3P Microphones in the Ear Plate Plane (45CC-9 and -10)	Microphone Assembly 69CC-3	Microphone Assembly 69CC-4
Frequency response	4 Hz – 70 kHz	
Dynamic range	39 dB(A) – 169 dB	44 dB(A) – 166 dB
IEC 60318-4 WS2P Microphones with Human-like Pinnae (45CC-14 and -15)	Microphone Assembly 69CC-5	Microphone Assembly 69CC-6
Frequency response	100 Hz – 10 kHz	
Dynamic range	25 dB(A) – 164 dB	25 dB(A) – 150 dB
IEC 60318-4 WS2P Microphones with Human-like Pinnae (45CC-16 and -17)	Microphone Assembly 69CC-7	Microphone Assembly 69CC-8
Frequency response	100 Hz – 20 kHz	
Dynamic range	25 dB(A) – 164 dB	25 dB(A) – 150 dB
IEC 60318-4 WS2P Microphones with Human-like Pinnae (45CC-18 and -19)	Microphone Assembly 69CC-7	Microphone Assembly 69CC-8
Frequency response	100 Hz – 50 kHz	
Dynamic range	44 dB(A) – 169 dB	44 dB(A) – 166 dB
Dimensions and weight		
Width between ears adjustable from	130 to 170 mm	
Height of headband holder adjustable	from 75 to 135 mm	
Horizontal position of headband holder	Adjustable, ± 5 mm	
Ear plate angle	4.5° (ISO 4869-3)	
Weight	3 kg	

For specification for the 44AA-1 and 44AB-1 Mouth Simulators, see page 78.



## GRAS 44AA & 44AB

### Mouth Simulators



A sound source, which simulates the acoustic field close to the human mouth and complies with the standards IEEE 269, 661 and ITU-T Rec. P51.

For testing telephone mouthpieces as well as other microphones. At the mouth reference point (MRP), which is 25 mm from the detachable lip ring, the minimum-continuous signal it can produce in 1/3-octave bands is 100 dB re. 20  $\mu$ Pa in the frequency range 100 Hz to 10 kHz.

44AA's loudspeaker accepts an external signal either directly or via its own built-in power amplifier.

44AB's loudspeaker accepts a signal from an external power amplifier directly via the BNC input.

The jigs RA0104 and RA0105 are included for calibration according to ITU-T Rec. P51 and IEEE 269. These are for use with 1/4" or 1/2" microphones on 1/4" preamplifiers.

RA0104 holds the microphone at 0° incidence (1/4" only) to the sound source, RA0105 at 90° incidence (1/4" or 1/2").

44AA-1 and 44AB-1 are special versions of 44AA and 44AB with the BNC connector positioned on the opposite side for proper mounting on the GRAS 45CC Test Fixture.

Specifications	44AA	44AB
Min. continuous output level at MRP	110 dB re. 20 $\mu$ Pa (200 Hz - 6 kHz) 100 dB re. 20 $\mu$ Pa (100 Hz - 16 kHz)	110 dB re. 20 $\mu$ Pa (200 Hz - 6 kHz) 100 dB re. 20 $\mu$ Pa (100 Hz - 16 kHz)
Loudspeaker	8 $\Omega$ / 10 W (max. continuous)	8 $\Omega$ / 10 W (max. continuous)
Amplifier	Gain: 10 dB / Input impedance: 20 k $\Omega$	- / -
Mouth opening	20 mm diameter	20 mm diameter
Lip ring: External diameter / Distance from mouth	48 mm / 10 mm	48 mm / 10 mm
Dimensions: Diameter / Height (with lip ring)	104 mm / 104 mm	104 mm / 104 mm

## The Gold Standard in In-Cabin Acoustic Testing

Accurate and repeatable data is critical when testing in-cabin acoustics—whether for tuning audio systems, analyzing NVH data, or ensuring design consistency across platforms.

The GRAS AutoArray PR0003 and PR0004 are purpose-built microphone arrays designed to simplify in-cabin acoustic testing. With a robust structure, precise positioning tools, and two field-proven configurations, they help reduce setup time, improve measurement repeatability, and ensure reliable results where they matter most.

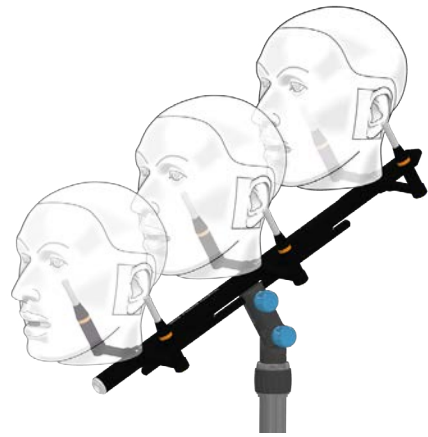

These arrays enable high-resolution spatial analysis of vehicle interiors, giving automotive OEMs and audio engineers the tools to quantify and enhance cabin soundscapes.

Designed specifically for in-cabin acoustic testing, the GRAS AutoArrays are ideal for:

- Audio system performance testing and characterization
- Audio system tuning and optimization
- Cabin acoustic benchmarking and comparison
- Sound field mapping and analysis
- In-cabin NVH (Noise, Vibration & Harshness) measurements

They can also be deployed in any acoustic testing scenario that benefits from multi-microphone array setups.

### GRAS PR0003

#### AutoArray Cross Configuration



❖ The GRAS PR0003 AutoArray is a rugged, six-microphone array purpose-built for accurate and repeatable in-cabin acoustic measurements. It features a "Cross" configuration based on widely adopted test setups like those used by Harman.

### GRAS PR0004

#### AutoArray AES Configuration



❖ The GRAS PR0004 AutoArray is a rugged, six-microphone array purpose-built for accurate and repeatable in-cabin acoustic measurements. It features an "AES" configuration, aligned with the AES TC-AA (Audio Engineering Society Technical Committee on Automotive Audio) guidelines.

## GRAS AL0030

### Production Line Acoustic Test Chamber



AL0030 Production Line Acoustic Test Chamber is an anechoic test chamber for acoustic production line testing of mobile devices, for example cell phones, tablets, Bluetooth speaker systems and similarly sized portable acoustic devices.

It is designed for quick and qualified acoustic test, including frequency response, THD, Rub & Buzz and microphone test, using optional sound source.

It provides a flexible platform that can be configured to suit specific requirements. It has a broad range of connections for injecting test and control signals to the Device Under Test (DUT). The platform can also be expanded with a larger drawer that provides up to 10 connections.

Main features are:

- Repeatable testing and reliable data
- Easy open/close for quick and safe change of DUT
- Flexible test jig for easy adjustment to new DUT
- Flexible microphone mounting for both front- and backside speakers as well as edge-mounted speakers
- High-quality, high-sensitive 46BL 1/4" CCP measurement microphone included
- Individually calibrated frequency response

AL0030 will speed up product development time significantly. It can be deployed almost anywhere and essentially offers a bench-top anechoic chamber providing highly repeatable data.

Specifications	AL0030
Frequency range*	100 Hz – 20kHz
Noise insulation (SIL)	> 25 dB (3rd octave)
Connector panel options:	
Small	8 configurable connections
Large	10 configurable connections
Operating temperature range	+ 5°C to + 40°C
Dimensions	Height: 52.8 cm Width: 42.4 cm Depth: 63.8 cm
Max. dimensions of DUT	300 x 200 mm (12" x 8")
Weight	39 kg

Connector Panel Options	
AE2197	BNC Socket, Female
AE2198	RCA Socket, Female
AE2199	XLR Connector 3 pol, Female
AE2200	Loudspeaker con. plug, SpeakON, 4 way
AE2201	S-VHS, Female, to S-VHS, Female
AE2202	1/4" jack, 3 pol
AE2203	D-sub 9 pin
AE2204	HDMI-Connector
AE2205	Ethernet connector
AE2207	USB-B adapter

\* The recommended useful frequency range for AL0030 is from 100 Hz to 20 kHz. It can be used down to 50 Hz, however, below 100 Hz phenomena like room gain can make measurements unpredictable, and therefore we recommend 100 Hz as a practical lower limit.

# PROCESS FOR how to build your own test chamber:

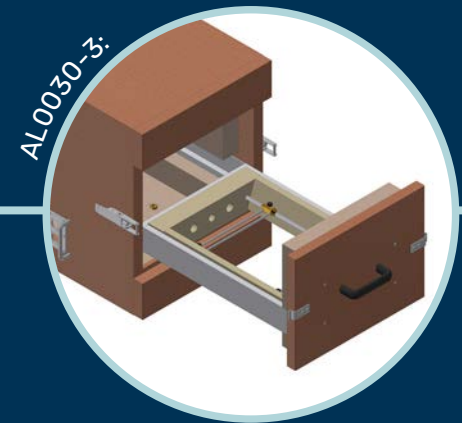
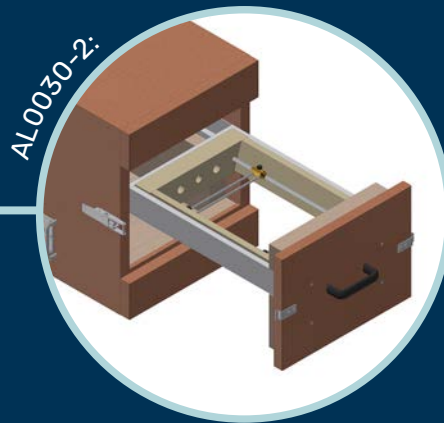
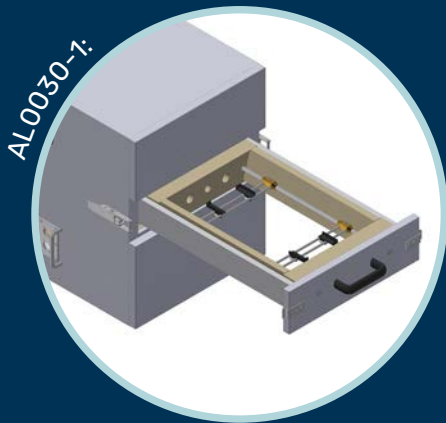

## 1. Select the drawer size:

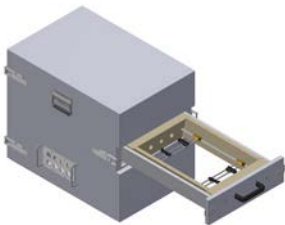

### **AL0030-1:**

#### **Small drawer**

Used for test of relative flat DUT's such as smartphones, tablets, hearing aids, etc.

Max DUT dimensions (WxDxH) 30 x 20 x 6,6 cm.

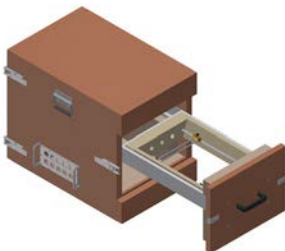

### **AL0030-2:**

#### **Large drawer with DUT holder in upper part of the chamber.**

Used for test of DUT's with relative higher height that benefit from a holder placed high in the test chamber. Such as speakers, smart speakers etc.

Max DUT dimensions (WxDxH) 30 x 20 x 22,8 cm. Height above holder is 11,9 cm.

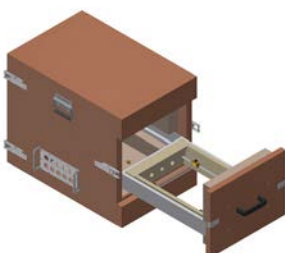

### **AL0030-3:**

#### **Large drawer with DUT holder in lower part of the chamber.**

Used for test of heigh DUT's that benefit from a holder placed low in the test chamber. Such as speakers, smart speakers etc.

Max DUT dimensions (WxDxH) 30 x 20 x 22,8 cm.

# Power Modules

Measurement microphones and preamplifiers require special voltages for supply and polarization. There are two different supply principles. One is for the Traditional LEMO (voltage-driven) preamplifiers, and one is for constant current power (CCP) preamplifiers. Acoustic measurements also often require special signal conditioning such as A-weighting or high-pass filtering. Amplification or attenuation of the signal may also be necessary.

Standard externally polarized condenser microphones require a stable polarization voltage of 200 V DC for proper operation. This polarization voltage may be turned off in the power modules for use with prepolarized microphones too.

A-weighting is the most commonly used form of frequency weighting in acoustic measurements. It approximates the sensitivity of the human ear, which results in a more subjective measurement of noise.

Low-frequency acoustic signals generated, for example by wind flow, may overload the input section of the analyzer and subsequent measurement chain. This can be avoided by removing frequencies below 20 Hz with the high-pass filter of a power module.

The wide range of GRAS power modules can fulfil these requirements. Some are simple supplies that give only the special voltages required, whereas others also include signal conditioning.

GRAS CCP power modules maintain a constant level of current for driving CCP transducers such as GRAS CCP preamplifiers, standard CCP microphone sets and special CCP microphones. Since the current is constant, the only thing that can vary with a CCP transducer under excitation is the supply voltage, which is analogous to its output signal.

Furthermore, since power is supplied via the same line as that used by the signal, only a coaxial cable is needed for connecting the transducer to the power module and subsequent analyzer.

There are also dedicated power modules for use only with GRAS low-noise measurement systems. They provide polarization and supply voltages for powering the special low-noise microphones and preamplifiers. The power modules are provided with a switch for selecting a response setting of either pressure or free-field.

Large systems for multi-channel acoustic measurements involving eight channels or more are most economically realized by using multi-channel power modules. Most GRAS power modules will fit into the optional GRAS 19" standard rack kit.

A combined power module and power amplifier is also available for electro-acoustic tests of smaller devices like receivers and mini speakers.

## GRAS 12AD

### 1-Channel Power Module



12AD is a 1-channel, battery-operated, microphone power module. It has a 7-pin LEMO 1B input connector for a microphone preamplifier and one BNC output socket. It can provide a polarization of 200 V for externally polarized or 0 V for prepolarized microphone cartridges.

A battery indicator is included to monitor battery condition as well as an input socket for an external power supply.

## GRAS 12AR

### 2-Channel Power Module



12AR is a 2-channel, battery-operated, microphone power module. It has two 7-pin LEMO 1B input connectors for microphone preamplifiers and two BNC output sockets. It can provide a polarization of 200 V for externally polarized or 0 V for prepolarized microphone cartridges.

A battery indicator is included to monitor battery condition as well as an input socket for an external power supply.

Specifications	12AD
Input Channels	7-pin LEMO 1B connectors
Output Channels	BNC socket
Preamplifier Supply	$\pm 15$ V
Output Impedance	Depends on preamplifier
Polarization Voltage	0 V or 200 V
Frequency Response	0.05 Hz – 200 kHz
Power Supply	4 x AA alkaline batteries (included) or 4.5 – 24 V DC mains adapter 115/230VAC) (not included)

Specifications	12AR
Input Channels	2 x 7-pin LEMO 1B connectors
Output Channels	2 x BNC sockets
Preamplifier Supply	$\pm 15$ V
Output Impedance	Depends on preamplifier
Polarization Voltage	0 V or 200 V
Frequency Response	0.05 Hz – 200 kHz
Power Supply	4 x AA alkaline batteries (included) or 4.5 – 24 V DC mains adapter 115/230 VAC) (not included)

## GRAS 12AK

### 1-Channel Power Module with Gain, Filters and SysCheck Generator



12AK is a 1-channel, battery-operated, microphone power module, amplifier and filter unit. It has a 7-pin LEMO 1B input connector for a microphone preamplifier and a BNC output socket. It has both instantaneous and latched overload indicators and a gain that can be set to 0dB, +10dB, +20dB, +30dB, +40dB or +50dB.

The A-weighting network fulfills the requirements of IEC 60651 for Type 0 and IEC 61672 Class 1 Sound Level Meters. The high pass filter is a 3-pole Butterworth filter with a cut-off frequency at 20 Hz.

A battery indicator is included to monitor battery condition as well as an input socket for an external power supply. It also has a built-in 1 kHz precision calibration generator with adjustable level for activating the SysCheck function in the 26AJ and 26AL preamplifiers. The generator can be activated either via a front-panel button or remotely via an input on the back of the module.

12 of these Power Modules can be mounted in the AK0040 Standard 19" Rack Kit.

Specifications	12AK
Input Channel	7-pin LEMO 1B connectors
Output Channel	BNC socket
Gain Settings	0 dB, +10 dB, +20 dB, +30 dB, +40 dB, +50 dB
Preamplifier Supply	28 V or 120 V
Output Impedance	30 Ω
Polarization Voltage	0 V or 200 V
Frequency Response	3.5 Hz – 200 kHz
A-weighting Network	IEC 60651 Type 0 and IEC 61672 Class 1
Power Supply	10 x AA alkaline batteries (included) or 12 – 18 V DC mains/line adapter for 115/230 VAC (included)

## GRAS 12AA

### 2-Channel Power Module with Gain, Filters and SysCheck Generator



12AA is a 2-channel, battery-operated, microphone power module, amplifier and filter unit. It has two 7-pin LEMO 1B input connectors for microphone preamplifiers as well as two BNC output sockets. Both channels have an overload indicator and a gain that can be set to -20dB, 0dB, +20dB or +40dB.

The A-weighting network fulfills the requirements of IEC 60651 for Type 0 and IEC 61672 Class 1 Sound Level Meters. The high-pass filters are 3-pole Butterworth filters with a cut-off frequency at 20 Hz.

A battery indicator is included to monitor battery condition as well as an input socket for an external power supply.

12 of these Power Modules can be mounted in the AK0040 Standard 19" Rack Kit.

Specifications	12AA
Input Channel	2 x 7-pin LEMO 1B connectors
Output Channel	2 x BNC socket
Gain Settings	-20 dB, 0 dB, +20 dB, +40 dB
Preamplifier Supply	28 V or 120 V
Output Impedance	30 Ω
Polarization Voltage	200 V or 0 V
Frequency Response	3.5 Hz – 200 kHz
A-weighting Network	IEC 60651 Type 0 and IEC 61672 Class 1
Power Supply	10 x AA alkaline batteries (included) or 12 – 18 V DC mains/line adapter for 115/230 VAC (included)

## GRAS 12AG

### 8-Channel Power Module with Gain, Filters and SysCheck Generator



12AG is an 8-channel mains/line operated power module, but can also be powered by an external DC supply. It is built for multi-channel acoustic measurements, using preamplifiers and condenser microphones.

Each channel offers a choice of linear response, A-weighting and high pass filters. The polarization voltage can be set to either 200 V or 0 V allowing the use of either externally polarized and prepolarized microphone cartridges. The preamplifier supply voltage can be selected internally to either 28 V or 120 V.

Each channel has a 7-pin LEMO 1B input connector for a microphone preamplifier, as well as indicators for instantaneous and latched overloads.

The gain in each channel can be selected individually in steps of 10 dB from 0 dB up to +50 dB. The high-pass filters are 3-pole Butterworth filters with a -1dB cut-off frequency at 20 Hz to remove unwanted low frequency signals, for example caused by wind-induced noise around the microphones. Two of these Power Modules can be mounted in the AK0040 Standard 19" Rack Kit.

Specifications	12AG
Input Channels	8 x 7-pin LEMO 1B connectors
Output Channels	8 x BNC sockets
Gain Settings	0 dB, +10 dB, +20 dB, +30 dB, +40 dB, +50 dB
Preamplifier Supply	28 V or 120 V
Polarization Voltage	0 V or 200 V
Frequency Response	3.5 Hz – 200 kHz
A-weighting network	IEC 60651 Type 0 and IEC 61672 Class 1
Output Impedance	30 Ω
Power Supply	12 – 18 V DC mains/line adapter for 115/230 VAC (included)

## GRAS 12AQ

**2-Channel Universal Power Module with Signal Conditioning and PC Interface**



12AQ is a 2-channel power module for powering microphone preamplifiers requiring a constant-current or constant voltage power supply. 12AQ is for general use in acoustic measurements as well as for intensity measurements, both in the laboratory and in the field. It has facilities for both manual control and remote control. Manual control is via front-panel switches and push buttons. Remote control is via RS-232 interface.

If a special filter function such as a HP-filter, LP-filter or BP-filter is required, it can easily be implemented in the module, as 12AQ is prepared with slots for extra filters.

## GRAS 12AL

**1-Channel CCP Power Module with A-weighting Filter**



12AL is a 1-channel CCP Power Module for powering microphone preamplifiers requiring a constant-current power supply, e.g., 26CB and 26CA. It can also power the 40SC Probe Microphone as well as the 40PH and 40PL Array Microphones.

12AL covers the frequency range from 1 Hz to 200 kHz and has a switchable A-weighting network and overload indicator. It is powered either by two internal batteries (LR6-AA) or by an external 3-6 V DC power supply (included).

Specifications	12AQ
Traditional preamp. input:	
Connector	7-pin LEMO
Power Supply	$\pm 15V$ or $\pm 60 V$
Polarization	0 V or 200 V
CCP Preamplifier Input:	
Connector	BNC coaxial
Power Supply	4 mA sourced at 28 V DC
Signal Output	BNC coaxial connector
Gain	Adjusted, steps of 10 dB from -20 dB to +70 dB
Frequency Range	2 Hz to 200 kHz $\pm 0.2$ dB
Filters	HP filter 20 Hz. A-weighting IEC 61672 Class 1
Control Interface to host	Smart RS-232, MSG line
Power Supply	6 x LR14 alkaline batteries (included) or 8 – 18 V DC mains adapter for 115/230 VAC (included)

Specifications	12AL
Input Channel	BNC socket
Output Channel	BNC socket
Transducer Supply Current	4 mA sourced from 28 V
Frequency Response	1 Hz – 200 kHz
A-Weighted Network	IEC 60651 Type 0 and IEC 61672 Class 1
Power Supply	2 x AA alkaline batteries (included) or 3 – 6 V DC mains adapter for 115/230 VAC (not included)

## GRAS 12AN

### 4-Channel Power Module



12AN is a 4-channel power module for general use. It is a cost-effective solution with direct coupling (no filters), and is therefore ideally suited for infra-sound measurements. It can be used with all standard LEMO microphone sets and standard front-ends or acquisition units.

## GRAS 12AX

### 4-Channel CCP Power Module



12AX is a 4-channel power module for production line testing. It has three gain settings for optimization of the signal-to-noise performance. It can be used with all standard CCP microphone sets and standard front-ends or acquisition units.

Specifications	12AN	12AX
Input Channels	4 x 7-pin LEMO 1B connector	4 x BNC sockets
Output Channels	4 x BNC sockets	4 x BNC sockets
Gain	-	0 dB, +20 dB, +40 dB
Preamplifier Supply	+/- 15 V	5 mA @ 28 V
Polarization	0 V or 200 V	0 V
Frequency Response	0.05 Hz – 200 kHz +/- 0.2 dB	1 to 300 kHz (+1/-3 dB @ Gain = 0 dB)
Power Supply (included)	4 x AA batteries or 6 – 20 V DC mains adapter for 115/230 VAC	6 – 20 V DC mains/line adapter for 115/230 VAC

## GRAS 12AU

### 1-Channel Universal Power Module with Signal Conditioning and Power Amplifier



12AU is a combined power module and power amplifier, optimized for production line testing of micro-speakers and receivers.

It will supply a CCP or a LEMO microphone set and condition the measured signal. In addition, it will drive a loud-speaker and continuously monitor the current and voltage for easy derivation of typical loudspeaker test parameters.

It is remotely controlled via its USB interface and, for this purpose, is delivered with a control program for Microsoft Windows®.

It can be mounted in a 19" rack.

Specifications	12AU
Traditional input	Connector 7-pin LEMO 1B series Power Supply $\pm 15$ V
CCP Input	Connector BNC Power Supply 28 V / 4 mA
Polarization	0 V / 200 V (remote controlled)
Output	BNC floating (2 k $\Omega$ /100 nF to power ground)
Gain	0 – 50 dB in 10 dB steps ( $\pm 0.2$ dB) (remote controlled)
Bandwidth (-3dB)	1 Hz to 100 kHz
Noise (relative to input) Input shorted ( $\geq 20$ dB gain) Input loaded with 20pF dummy mic.	< 1.5 $\mu$ Vrms (20 Hz – 20 kHz) < 5 $\mu$ Vrms (20 Hz – 20 kHz)
High Pass Filter (remote controlled)	1 Hz (1. order) or 20 Hz (3. order Butterworth)
Max Output Current	+/- 1.4 A
Overload Detection (voltage & current)	LED indicators (remote controlled reading and reset)
Current Output (voltage/current ratio)	1 V DC/1 A or 10 V DC/1 A
Power Supply	115/230 VAC

## GRAS 12BA, 12BB and 12BE

### 1-, 2-, and 4-Channel CCP Power Modules with TEDS



GRAS 12BA, 12BE and 12BB are USB-powered CCP power modules with one to four channels, respectively. They provide power to microphone sets without signal degradation, gain modification, or attenuation.

Power for these modules is provided through the USB cable using a USB 2.0 or USB 3.0 port on the PC and a USB-C port on the power module.

They are a simple and cost-effective interface between TEDS-enabled measurement microphones and any Audio Precision APx series analyzer that will automatically extract TEDS data. They also enable full SysCheck2TM functionality when connected to APx500 release v7.0 Measurement Software and an Audio Precision APx series analyzer, or with an Audio Precision APx series analyzer with CCP and TEDS read/write capability.

However, these power modules can also be used with other brands. In this case, a TEDS utility program provides access to TEDS data on a PC.

Specifications		12BA	12BE	12BB
Input Channels	BNC socket	1	2	4
Output Channels	BNC socket	1	2	4
Preamplifier Supply	mA	4 @ 24 V		
Polarization Voltage	V	0		
Frequency Response	Hz	10 – 200 k		
Power Supply	V via USB	5		

## GRAS 12BC, 12BD and 12BF

### 1-, 2-, and 4-Channel LEMO Power Modules with TEDS



GRAS 12BC, 12BF and 12BD are USB-powered LEMO power modules with one to four channels, respectively. They provide power to microphone sets without signal degradation, gain modification, or attenuation.

Power for the 12BB is provided through the USB cable using a USB 2.0 or USB 3.0 port on the PC and a USB-C port on the power module. An AC power supply to drive the power module from a wall outlet is also included.

It is intended as a simple and cost-effective interface between TEDS-enabled measurement microphones and any Audio Precision APx series analyzer that will automatically extract TEDS data for seamless integration.

However, it can also be used with other brands. In this case, a utility program provides access to TEDS data on a PC.

Specifications		12BC	12BF	12BD
Input Channels	LEMO	1	2	4
Output Channels	BNC socket	1	2	4
Preamplifier Voltage	V DC	±15 @ 30 mA		
Polarization Voltage	V	200		
Frequency Response	Hz	10 – 200 k		
Power Supply	V via USB	5		

## GRAS 12HF

### 1-Channel Power Module for Low-noise Systems



12HF is a power module for single-channel, low-noise measurements using the matched, low-noise preamplifiers and high sensitive microphones of GRAS 40HF, 40HH and 40HT Low-noise Microphone Systems.

#### 12HF provides:

- Polarization voltage (200 V) for the condenser microphone
- Voltage supplies ( $\pm 15$  V) for powering the microphone preamplifier
- A response setting of pressure or free field

When fitted with the above matched preamplifiers and microphones, the 12HF supports the specifications of GRAS Low-noise Microphone Systems.

## GRAS 12HM

### 10-Channel Power Module for Low-noise Systems



12HM is a 10-channel power supply for multi-channel low-noise measurements with GRAS 40HF, 40HH and 40HT Low-noise Microphone Systems. With these, the 12HM can be used in sound-power measurements of low-noise products, such as disk drives, under anechoic and/or semi-anechoic conditions.

#### 12HM provides:

- Polarization voltages (200 V) for up to 10 condenser microphones
- Voltage supplies ( $\pm 15$  V) for powering up to 10 microphone preamplifiers
- Individual response setting, pressure or free field, for each channel
- Individual gain adjustment of  $\pm 3$  dB for each channel.

When connected to the above matched preamplifiers and microphones, each channel supports the specifications of GRAS Low-noise Microphone Systems.

Specifications	12HF	12HM
Input Channel	7-pin LEMO EGA 1B	10 x 7-pin LEMO EGA 1B
Output Channel	BNC coaxial	10 x BNC coaxial
Output Impedance	30 $\Omega$	30 $\Omega$
Polarization Voltage	200 V	200 V
Gain Adjustment/Channel	-	$\pm 3$ dB
Channel Separation	-	> 90 dB
Power Supply	4 x LR14 (C) batteries or (included) 6 – 20 V DC mains adapter for 115/230 VAC (included)	Mains adapter for 115 or 230 VAC – max. 35 VA (included)
Dimensions	Height: 132.6 mm (5 1/4") Width: 34.6 mm (1.3") Depth: 196 mm (7.7")	Height: 132.6 mm (5 1/4") Width: 420 mm (16 1/2") Depth: 196 mm (7.7")
Weight	620 g (1.3 lbs)	5.5 KG (12 lbs)

# | Accessories

GRAS Sound & Vibration offers a wide range of standard accessories in the form of cables, adapters, wind-screens and tripods for use in measuring setups.

These can be broadly divided into accessories for microphones, preamplifiers and outdoor microphones. Some are included with certain products, some are available as extras. All can be ordered individually.

The brief description given here as well as the information available on [www.grasacoustics.com](http://www.grasacoustics.com) will help you select what you need for your particular setup.

At all events, feel free to contact your local partner if you need advice or further information.

## 1/2" Microphone to 1/4" Preampfier

- AF0008** Adapter for 1/2" Mic. and 1/4" Preamp.
- GR0010** Adapter for 1/2" Mic. and 1/4" Preamp.
- RA0003** Adapter for 1/2" Mic. and 1/4" Preamp.



AF0008



GR0010



RA0003



For any standard 1/2" microphone and 1/4" preampfier. **AF0008**, included with 26AB. **GR0010**, included with 26AC, 26AL, 26AR and 26CB. **RA0003** for any standard 1/2" mic. of other brand and a GRAS 1/4" preampfier.

## 1/8" Microphone to 1/4" Preampfier

- RA0063** Adapter for 1/8" Mic. and 1/4" Preamp.
- RA0082** Adapter for 1/8" Mic. and 1/4" Preamp., long



RA0063



RA0082



Adapters for using a 1/8" microphone with a 1/4" preampfier. Can be used with any standard 1/8" microphone and 1/4" preampfier such as 26AC.

**RA0063.** To reduce attenuation of the microphone signal, the guard ring of the preampfier is extended through RA0063.

**RA0082.** Its extended length improves high frequency performance by reducing diffraction effects.

## 1/4" Microphone to 1/2" Preampfier Adapter

- RA0019** Adapter for 1/4" Mic. and 1/2" Preamp.



Inline stub adapter for connecting 1/4" microphone to 1/2" preampfier

## 1" Microphone to 1/2" Preampfier Adapter

- RA0017** Adapter for 1" Mic. and 1/2" Preamp.
- RA0073** Adapter for 1" Mic. and 1/2" Preamp.



RA0017



RA0073



**RA0017.** Head adapter for any standard 1" microphone and 1/2" preampfier. **RA0073.** For 1" mic. with 1/2" preamp. The influence of RA0073 on the acoustic field is minimal.

### Right-angled Adapters (90°)

- RA0001** 1/2" microphone to 1/4" preamplifier
- RA0002**
- RA0190** 1/2" microphone to 1/2" preamplifier
- RA0006** 1/4" microphone to 1/4" preamplifier



RA0001



RA0002



RA0190



RA0006

Right-angled adapters. Can be used with all standard microphones and preamplifiers.

### Tools for Gripping Microphones

- RA0161** Tool for gripping 1" Microphone
- RA0081** Tool for gripping 1/2" Microphone
- RA0200** Tool for gripping 1/4" Microphone
- RA0210** Tool for gripping 1/8" Microphone



With soft jaws for safely holding the microphone when unscrewing the protection grid or preamplifier.

### Nosecones

- RA0020** 1/2" Nosecone
- RA0020-A** 1/2" Nosecone, aluminum for lightness
- RA0022** 1/4" Nosecone
- RA0173** 1/8" Nosecone



RA0020



RA0020-A



RA0022



RA0173

Nosecones for replacing the standard protection grid of a microphone when making acoustic measurements in high-speed laminar airflow. The tip should be pointed upstream in the laminar flow to reduce turbulence created by the microphone itself.

### 1/4" Mic. to 1/4" Preamp., for intensity Probe

- RA0007** Adapter for 1/4" Mic. and 1/4" Preamp.



7.5 mm straight adapter for placing between a 1/4" microphone and a 1/4" preamplifier. Included with GRAS 40BI 1/4" Intensity Microphone set.

### GRAS RA0132

#### Dehumidifier for 1/2" Microphones



For use at high humidity levels, only with rear-vented 1/2" microphones. An indicator on the side of the dehumidifier shows when it needs to be dried out.

## Capacitive Input Adapters

- RA0062** 20 pF Input Adapter for 1/2" preamplifier
- RA0062-S1** 50 pF Input Adapter for 1/2" preamplifier
- RA0080** 6 pF Input Adapter for 1/4" preamplifier



❖ **RA0062** is a 20pF input adapter for 1/2" preamplifiers. One end screws on to a 1/2" preamplifier and the other end has a BNC input connector. This enables connecting a signal generator to the input of the preamplifier. RA0062 can be used as a 20pF dummy load when short circuiting the BNC input.

**RA0062-S1** is a 50pF input adapter for 1/2" preamplifiers. One end screws on to a 1/2" preamplifier and the other end has a BNC input connector. This enables connecting a signal generator to the input of the preamplifier. RA0062 can be used as a 50 pF dummy load when short circuiting the BNC input.

**RA0080** is a 6pF input adapter for 1/4" preamplifiers. One end screws on to a 1/4" preamplifier and the other end has a Microdot (UNF 10-32) input connector. This enables connecting a signal generator to the input of the preamplifier. RA0080 can be used as a 6pF dummy load when short circuiting the Microdot input.

## Inline Input Adapters

- AG0001** 7-pin LEMO to B&K
- AG0002** CCP Input Adapter
- AG0003** CCP to XLR Adapter
- RA0083** BNC to 7-pin LEMO
- RA0125** Microdot Input to 1/2" Preamplifier



❖ **AG0001** is an adapter for a 7-pin LEMO connector and a traditional 7-Pin B&K microphone input connector.

**AG0002** is an inline adapter for using a CCP preamplifier with a (constant-voltage) GRAS Power Module. One end plugs straight into the Power Module's input LEMO connector and the other end has a BNC socket for making a connection with a CCP preamplifier, e.g., CCP preamplifiers 26CB, 26CC (1/4") and 26CA, 26CF (1/2").

**AG0003** is an adapter for connecting a CCP compatible preamplifier to an input module with XLR connector and Phantom Supply (CCP) supply. AG0003 is provided with a BNC input connector.

**RA0083** is for utilising the signal and signal-ground pins only of the 7-pin LEMO input of a preamplifier power supply.

**RA0125** is an adapter for using a Microdot (UNF 10-32) input to a standard 1/2" preamplifier such as the 26AK. Useful when a high input impedance is required for transducers such as hydrophones and accelerometers. Including GR0010, it can be used with 1/4" preamplifiers as well, f.ex. 26AC.

## Microphone protection grid

- RA0524** 1/8" Microphone protection grid
- RA0526** 1/4" Microphone protection grid
- RA0527** 1/2" Microphone protection grid
- RA0177** 1" Microphone protection grid



RA0524 RA0526 RA0527 RA0177

## GRAS RA0567

**1/4" Microphone protection grid for 47BX**



A 1/4" protection grid designed for the GRAS 47BX flush-mount microphone set. Shown in the image with the 47BX microphone set (not included).

## GRAS RA0340

**1/2" Dust, Oil, Water and shock resistant microphone protection grid for 146AE microphone set**



Dust, oil water and shock resistant microphone protection grid for the GRAS 146AE microphone set. Pack of 5 units of this protection grid are available as GRAS **RA0354**.

## GRAS RA0390

**1/2" Dust, Oil, Water and shock resistant microphone protection grid for 147AX microphone set**



Dust, oil, water and shock resistant microphone protection grid for the GRAS 147AX microphone set. Shown in the image with a GRAS 147AX microphone set (not included).

## GRAS RA0360

**1/2" Dust, Oil, Water and shock resistant microphone protection grid for 147EB microphone set**



1/2" dust-, oil-, water-, and shock-resistant microphone protection grid designed for the GRAS 147EB microphone set. The RA0360 works in conjunction with the 1" RA0355 protection grid for enhanced protection.

## GRAS RA0355

**1" Dust, Oil, Water and shock resistant microphone protection grid for 147EB microphone set**



1" dust-, oil-, water-, and shock-resistant microphone protection grid designed for the GRAS 147EB microphone set. The RA0355 works in conjunction with the 1/2" RA0360 protection grid for enhanced protection.

## GRAS RA0091

**Insulated 1/2" Microphone Protection Grid**



For avoiding ground loops, e.g., with RA0085 in telephone testing set-ups using 43AD Ear Simulator Kit.

## GRAS RA0424

1/2" Microphone protection grid for 47AX/47AD



A 1/2" protection grid designed for the GRAS 47AX and 47AD flush-mount microphone sets. Shown in the image with the 47AX microphone set (not included).

## GRAS RA0425

1/4" Microphone protection grid for 46BC/46BL-1/40PI



A 1/4" protection grid designed for the GRAS 46BC, 46BL-1 and 40PI microphones. Shown in the image with the 46BC microphone set (not included).

## GRAS RA0427

1/2" Microphone protection grid with M3 thread on top



1/2" microphone protection grid with M3 thread on top

## GRAS RA0428

1/4" Microphone protection grid with M1,6 thread on top



1/4" microphone protection grid with M1,6 thread on top

## Rain Protection Caps

**RA0131**

Rain-protection cap for 1/2" microphone

**RA0127**

Rain-protection cap for 1/4" microphone

**RA0092**

Rain-protection cap for array microphone



RA0131



RA0127



RA0092



**RA0131** includes a protection grid which has a central matching threaded stud.

**RA0127** includes a protection grid which has a central matching threaded stud.

**RA0092** is for use with GRAS array microphones 40PH and 40PL.

## Rain-resistant Grids

**RA0262**

Rain-resistant grid for 1/2" microphone

**RA0336**

Rain-resistant grid for 1/4" microphone

**RA0312**

Rain-resistant grid for 1/8" microphone

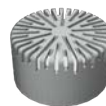

RA0262



RA0336



RA0312



These protection grids shield the microphone diaphragm from light rain. While they resemble standard GRAS microphone protection grids, they feature an inner layer of rain-resistant material for added protection.

## Microphone Tripods with 1/4" UNC-20 Threads

**AL0004** Small Lightweight Microphone Tripod

**AL0006** Microphone Tripod



- Standard mounting thread (1/4" UNC-20)
- Crank-adjusted centre column
- Rubber feet
- Adjustable tripod legs with locks

**AL0004.** Compact, light-weight tripod.

- Max. height 123 cm
- Retracted 41 cm

**AL0006.** A versatile and robust tripod. As AL0004, but stronger and more stable.

- Max. height 161 cm
- Retracted 65 cm

## Microphone Holders—Stainless Steel, Adjustable

**RA0093** 1/2" microphone holder, 5-click

**RA0096** 1/4" microphone holder, 5-click

**RA0096-S1** 7 mm Microphone Holder, 5-click

**RA0094** Holder for Array Module, 3-click



RA0093



RA0096



RA0096-S1



RA0094



Adjustable, high quality, stainless steel tripod adapters with 180° angular adjustment in steps of 45°.

## Microphone Holders—Stainless Steel, Fixed

**AL0012** 1/2" Microphone Holder

**AL0013** 1/4" Microphone Holder



AL0012



AL0013



For mounting microphone sets on tripods with a standard 1/4" UNC-20 thread. Can be used with the swivel head AL0005.

## Microphone Holders—POM, Fixed

**AL0008** 1/2" Microphone Holder, POM

**AL0028** 7 mm Microphone Holder, POM

**AL0029** 1/4" Microphone Holder, POM

**AL0035** 1/8" Microphone Holder, POM (not shown)



AL0008



AL0028



AL0029

## GRAS AL0005

**Swivel Head**



Lightweight swivel head for microphone holders, with a standard 1/4" UNC-20 thread.

## GRAS AL0003

### Tripod Adapter for Microphones



AL0003 is an adapter with a swivel head for mounting 1/2" or 1/4" microphone sets on tripods with a standard 1/4" UNC-20 thread. Designed to minimize diffraction.

## 3/8" UNC-16 to 1/4" UNC-20

- SK0017 Tripod Thread Insert
- SK0057 Tripod Conversion Screw



SK0017. For adapting a female 3/8" UNC-16 thread to a male 1/4" UNC-20 thread.  
 SK0057. For adapting the 3/8" UNC-16 thread of a tripod to 1/4" UNC-20 thread.

## GRAS RA0504

### 1/2" GoPro Adapter



A specially-designed adapter that makes it possible to use the whole range of GoPro mounting accessories for mounting 1/2" microphone sets.

## GRAS AL0007

### Clips for 1/4" Intensity Microphones



Set with microphone clips 12 mm and 25 mm for side-by-side mounting of a pair of 1/4" intensity microphones.

## MagMount™ Discs for 147AX

- RA0392-1 Pack of mounting discs, 5 pcs
- RA0392-10 Pack of mounting discs, 10 pcs



Discs for magnetic mounting of the 147AX. They can be screw-mounted or attached with glue or double-sided adhesive tape (included). The center tap ensures precise mounting of the 147AX.

## GRAS RA0302

### Removal Tool for 1/2" and 1/4" Flush-mount Microphones



GRAS RA0302 is a removal tool for 1/2" and 1/4" flush-mount microphones. This product is compatible exclusively with GRAS 47AX, 47AD, and 47BX flush-mount microphones.

### GRAS RA0501

Adapter for flush mounting of 1/2" and 1/4" microphones



RA0501

### GRAS RA0502



RA0502



Non-conductive mounting adapter for 1/2" and 1/4" flush-mount microphone sets. RA0501 is designed for 47AD and 47AX, while RA0502 is made for 47BX.

### GRAS RA0530

Adapter with wire mesh for Flush mounting of 1/4" microphones



The GRAS RA0530 is an adapter for flush mounting of 1/4" microphones such as 46BD or 46BE.

### GRAS RA0531

Adapter with open diaphragm for flush mounting of 1/4" microphones



The GRAS RA0531 is an adapter for flush mounting of 1/4" microphones. The image shown here depicts the RA0531 in use with a GRAS 46BE microphone set (sold separately).

### GRAS RA0533

Removal Tool for 1/4" microphone from flush mount adapters



RA0533 is designed to remove microphone from inside the GRAS RA0530 and RA0531 adapters for flush-mount of 1/4" microphones, when the microphone capsule is separated from the preamplifier.

## Mounting UTP Microphone

### Hard Fairing for 48LA/LX-1



RA4810



DB0475

- RA4810** Hard Fairing for 48LA/48LX-1
- RA4810-2** Hard Fairing, 10-pack
- RA4810-10** Hard Fairing, 50-pack
- DB0475** Self-adhesive Mounting Pad for Hard Fairing



The hard fairing has click mount for easy microphone installation. Double-sided self-adhesive mounting pads are included.

### Soft Fairing for 48LA/LX-1



RA4811



DB0521

- RA4811** Soft Fairing Mounting Kit for 48LA/48LX-1
- RA4811-2** Soft Fairing Mounting Kit, 10-pack
- DB0521** Self-adhesive Mounting Pad for Hard Fairing

### Tape for UTP Line Arrays

- DB0507** Mounting tape for 48X-series Line Arrays



## GRAS RA0077

### NBS 9-A Coupler Adapter for 1/2" Microphone



RA0077 is an adapter for using a 1/2" microphone in the NBS 9-A Coupler RA0075.

## Random-incidence Correctors

**RA0122** For 1/2" free-field microphones

**RA0357** For 146AE 1/2" Free-field Rugged Microphone set



For use with 1/2" Free-field microphones when measuring in random-incidence sound fields.

## GRAS RA0117

### Coupler Adapter for 1/2" to 1/4" Microphone



RA0117 is an adapter for mounting a 1/4" microphone in couplers designed for 1/2" microphones.

## 20 dB Attenuators

**RA0016** For externally polarized microphones

**RA0018** For prepolarized microphones



RA0016



RA0018



RA0016 and RA0018 are 20 dB attenuators for inserting between a 1/2" microphone and preamplifier. They attenuate the output signal of the microphone by 20 dB in order to avoid overloading the preamplifier or input module.

## Transmitter Adapters

**RA0067** For 1/2" prepolarized microphones

**RA0086** For 1/4" ext. polarized microphones



RA0067



RA0086



RA0067 and RA0086 enable microphones (typically a 40BP 1/4" ext.pol. or 40AD 1/2 prepol.) to be used as high impedance sound sources. They take a calibration signal directly from a signal generator.

This makes the microphone behave like an electrostatic loudspeaker which, in a coupler, has a frequency response as good as when used as a microphone. The RA0067 can also be used with externally polarized microphones when used with 14AA Actuator Amplifier, which superimposes + 200 VDC polarization on the calibration signal.

**RA0067** has a BNC connector

**RA0086** has a microdot connector.

## GRAS AC0001

### Calibration Control Box for 41AM/41CN



AC0001 is a control box with local and remote facilities for switching on/off the actuator calibration of 41AM and 41CN Outdoor Microphone Systems. It also has a BNC output for analyzing the signals from these Outdoor Microphone Systems. It can be connected to a 12 - 18 V DC mains/line adapter for powering 41AM and 41CN.

## GRAS AM0033

### Tripod Adapter



For mounting 41AM/41CN Outdoor Microphones (fitted with Pole Adapter AM0029) on a tripod. Has 1 1/2" RG (ISO 228/1) male thread on top and 3/8" UNC-16 female thread at the bottom.

## GRAS RA0087

### Special Key



Used when dismantling the microphone assembly of the GRAS 41AM and 41CN Outdoor Microphone Systems.

## GRAS AM0037

### Transport Protection Cap



For protecting the microphone assembly in GRAS 41AM/41CN Outdoor Microphones.

## GRAS AM0029

### Pole Adapter



For mounting 41AM/41CN Outdoor Microphones on a pole. Has 1 1/2" RG (ISO 228/1) female thread. Also used with the Tripod Adapter AM0033 for mounting an Outdoor Microphone on a tripod.

## GRAS AM0038

### Multi Spanner/Wrench



For dismantling the microphone assembly of 41AM/41CN Outdoor Microphones.

CABLES FOR OUTDOOR MICROPHONES  
- visit [www.grasacoustics.com](http://www.grasacoustics.com)

## GRAS AM0009

### Windscreens for 41AM/41CN



AM0009 is a set of five open-cell-structure foam windscreens for mounting on 41AM and 41CN Outdoor Microphone Systems.

## GRAS RA0009

### Adapter for Pistonphone calibration



RA0009 is an adapter for calibrating 41AM Outdoor Microphone System. It fits over the rain protection cap for 41AM and permits in-situ calibration using a pistonphone such as 42AA.

## GRAS AM0052

### Complete Windscreen/Birdspike for 41AM/41CN



AM0052 is a windscreen, complete with anti-bird spikes, for mounting on the 41AM and 41CN Outdoor Microphone Systems.

## GRAS RA0041

### Adapter for Pistonphone Calibration



RA0041 is an adapter for calibrating the 41CN Outdoor Microphone. It fits over the rain protection cap for 41CN and permits in-situ calibration using a pistonphone such as 42AA.

## GRAS AM0089

### Large Windscreen for 41AM/41CN



Spherical windscreen for 41AM and 41CN Outdoor Microphone Systems. Fits directly over the existing windscreen, accommodating the anti-bird spikes. Open-cell foam structure, 150 mm diameter.

## GRAS AE0001

### Male Plug for 41AM/41CN



6-pin LEMO FFA.2S.306 male plug as supplied with 41AM/41CN

## IEC60318-4 Ear Simulator—Accessories for Testing of Hearing Aids and In-ear Headphones

**GR0435** In-ear Adapter

**RA0088** In-ear Adapter

**GR0436** Tube Stud

**RA0566** Exterior Ear Canal and Union Nut kit for "711-style" coupler



GR0435



GR0436



RA0088



RA0566

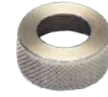

These accessories are compatible with any GRAS 711-style ear simulator for mounting hearing aids or in-ear headphones. RA0566 parts come standard with all GRAS 711-style ear simulators.

## IEC60318-4 Ear Simulator—Accessories for Testing of BTE Hearing Aids

**GR0437** Ear-mould Simulator

**GR0440** Tube stud

**GR0438** Union nut

**GR1176** Gasket



GR0437



GR0438



GR0440



GR1176

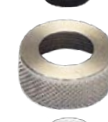

For testing of BTE hearing aids with an IEC60318-4 Ear Simulator, the items shown above are needed.

The illustration to the right shows the context in which they are used.

## IEC60318-5 1/2" 2cc Coupler—Accessories for Testing of ITE Hearing Aids

**GR0315** Gasket

**GR0319** Tube Adapter

**GR0317** Ear-mould Adapter

**GR0320** Union nut

**GR0318** Tube Adapter

**GR0321** In-ear Adapter



GR0318



GR0315



GR0317



GR0319



GR0320



GR0321



For testing of ITE hearing aids with a RA0038 1/2" IEC60318-5 Ear Simulator, the items shown above are needed.

The illustration to the right shows the context in which they are used.

## IEC60318-5 1" 2cc Coupler—Accessories for Testing of ITE Hearing Aids

<b>GR0316</b>	Union nut	<b>RA0017</b>	1/2" to 1" Adapter
<b>GR0723</b>	Tube Adapter	<b>RA0114</b>	1/4"-button Adapter
<b>OR5003</b>	O-ring	<b>RA0115</b>	In-ear Adapter
<b>OR5389</b>	O-ring		



For testing of ITE hearing aids with an RA0113 1" IEC60318-5 Ear Simulator, the items shown above are needed. The illustration to the right shows the context in which they are needed.

## GRAS RA0052

### Test Jig



For use with GRAS couplers and ear simulators. It has an adjustable spring-loaded arm to exert a variable force on the test object.

## GRAS RA0070

### Test Base for Ear Simulators



Test base for GRAS ear simulators and couplers.

## GRAS RA0058

### 1/2" to 1" Microphone Adapter



Converts a 1/2" microphone (with grid removed) into a 1" microphone's dimensions (with grid). Allows mounting of 1" microphone protection grid. Typically used with 45CA Hearing-protector Test Fixture.

## GRAS RA0076

### Adapter for NBS 9-A Coupler RA0075



RA0076 is a thread adapter exclusively for use in connection with RA0052 Test Jig. It can also be used when upgrading the 43XX Series Ear Simulator Kits, except 43AF, where it is included.

### GRAS RA0116

#### Adapter for 1/2" Microphone



For use with RA0113 2cc Coupler.

### GRAS KB0110 & KB0111

#### Ear-mould Simulators



Ear-mould simulator for connecting a coupler holder to a BTE hearing aid via 2 mm (KB0110) or 3 mm (KB0111) plastic tubing.

### GRAS RA0172

#### Pinna Holder Kit for 45CA



Designed for use with the 45CA test fixture when configured with IEC 60318-4 ("711-style") ear simulators and pinnae. This set includes one plate, one ear canal extension, and the necessary screws and key for installation.

### GRAS RA0251

#### GRAS KEMAR Retrofit Kit for Binaural Hearing Aid Test

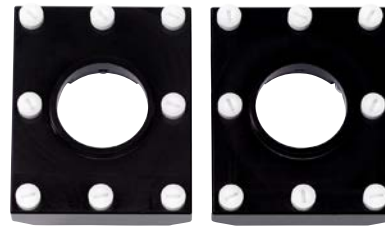

For testing of binaural hearing aids using RF communication, POM versions of the straight and the tapered ear canal extensions are available. To obtain the desired effect of non-interference with RF communication inside the head, KEMAR must also be fitted with POM ear holder plates. These are included.

### Ear Canal Extensions and Ear Microphone Holders

#### RA0237

#### RA0240



RA0237



RA0240

#### RA0238

#### RA0241



RA0238



RA0241

The following accessories can be used with KEMAR 45BB and 45BC, and 43AG test fixtures.



RA0249



RA0250

### Ear Canal Extensions and Ear Mic Holders

RA0237	Straight ear canal extension kit (2 pcs).
RA0238	VA-tapered ear canal extension kit (2 pcs)
RA0240	RA0240 Long holder for 1/2" microphones (2 pcs)
RA0241	RA0241 Short holder for 1/2" microphones (2 pc)

### Ear Canal Extensions (POM versions)

RA0249	Straight POM Ear Canal kit for Kemar, $\varnothing$ 7.5 mm, 8.3 mm long. Standardized according to IEC60318-7
RA0250	Tapered POM Ear Canal Kit for Kemar. $\varnothing$ 9.85 tapering down to $\varnothing$ 7.5 mm, 7.4 mm long

## KEMAR Pinnae for GRAS 45BB, 45BC and 43AG



Standard Pinnae, Soft		Standard Pinnae, Hard	
KB1060	Small Right Pinna, 35 Shore 00	<b>KB0060</b>	Small Right Pinna, 55 Shore 00
KB1061	Small Left Pinna, 35 Shore 00	<b>KB0061</b>	Small Left Pinna, 55 Shore 00
KB1065	Large Right Pinna, 35 Shore 00	<b>KB0065</b>	Large Right Pinna, 55 Shore 00
KB1066	Large Left Pinna 35, Shore 00	<b>KB0066</b>	Large Left Pinna, 55 Shore 00
Sound Quality/Wide Aperture Pinnae, Soft		Sound Quality/Wide Aperture Pinnae, Hard	
<b>KB1068</b>	Small Right Pinna 35, Shore 00	<b>KB0068</b>	Small Right Pinna, 55 Shore 00
<b>KB1069</b>	Small Left Pinna 35, Shore 00	<b>KB0069</b>	Small Left Pinna 55, Shore 00
<b>KB1090</b>	Large Right Pinna, 35 Shore 00	<b>KB0090</b>	Large Right Pinna, 55 Shore 00
<b>KB1091</b>	Large Left Pinna, 35 Shore 00	<b>KB0091</b>	Large Left Pinna, 55 Shore 00
Anthropometric Pinnae		3-D Simulation of KEMAR with Pinnae	
<b>KB5000</b>	Large Right Anthropometric Pinna, 35 Shore 00	<b>KB3000</b>	45BB with Large Pinna, step file
<b>KB5001</b>	Large Left Anthropometric Pinna, 35 Shore 00	<b>KB3001</b>	45BB with Small Pinna, step file
<b>KB5002</b>	Large Right (mirrored left) Anthro. Pinna, 35 Shore 00	<b>KB3002</b>	45BB with Anthropometric Pinna, step file

## Pinnae for GRAS 45CA and 45CC



Standard Soft, and Anthropometric Pinnae		Standard Hard Pinnae	
<b>KB1070</b>	Large Right Pinna, 35 Shore 00	<b>KB0070</b>	Large Right Pinna, 55 Shore 00
<b>KB1071</b>	Large Left Pinna, 35 Shore 00	<b>KB0071</b>	Large Left Pinna 55, Shore 00
<b>KB5010</b>	Right Anthropometric Pinna for 45CA, 35 Shore 00	<b>KB0072</b>	Small Right Pinna, 55 Shore 00
<b>KB5011</b>	Left Anthropometric Pinna for 45CA, 35 Shore 00	<b>KB0073</b>	Small Left Pinna 55, Shore 00

## Pinnae for GRAS 45CB



Pinnae for 45CB Ansi Head	
<b>KB0077</b>	Large Right Pinna, 55 Shore 00
<b>KB0078</b>	Large Left Pinna, 55 Shore 00

## Couplers for Pistonphones

- RA0023\*** 1" coupler for pistonphone
- RA0048\*** 1/2" coupler for pistonphone



Couplers for GRAS pistonphones.

## 1/2" Adapters for Pistonphones

- RA0049** 1/2" adapter for 1/4" microphone
- RA0069** 1/2" adapter for 1/8" microphone



Adapters for calibrating 1/4" and 1/8" microphones with a GRAS pistonphone fitted with a 1/2" Coupler.

## Calibration Adapters for 146AE and 147AX

- RA0341** Calibration adapter for 146AE
- RA0391** Calibration adapter for 147AX



For calibration of 146AE and 147AX respectively.

## GRAS RA0119

### Pistonphone Adapter



A pistonphone adapter for calibration checking the GRAS RA0056 and RA0057 pinna simulators when used together with a IEC 60318-4 "711-syle" ear simulator.

## Couplers for Two-port Calibration

- RA0024\*** Coupler for two-port Calibration
- RA0042** Coupler for two-port Calibration, high pressure



Two-port high couplers for comparison calibrations between two 1/2" microphones; one of which is a reference microphone. Can also be used in measuring the P-I (Pressure-Intensity) Index of intensity probes at 250 Hz.

**RA0024** is for use with 42AA and 42AP Pistonphones.  
**RA0042** is a high-pressure version for use with the 42AC Pistonphone.

## GRAS RA0090\*

### 94 dB Pistonphone Coupler



A large-volume Coupler for enabling 43AP Pistonphone to produce a sound pressure level of 94 dB instead of 114 dB re. 20  $\mu$ Pa. Essential when calibrating highly sensitive low-noise measuring systems, which would otherwise be overloaded by 114 dB. This pistonphone coupler is designed exclusively for calibrating low-noise microphones, such as the GRAS 40HF, 40HH, 40HL, 40HT, and 47HC. It is not suitable for use with low-noise ear simulators, including the GRAS 43BB product family.

\*Coupler and pistonphone unit must be calibrated together at the GRAS Calibration Lab.

## GRAS OP0023

**Kit for Sensitivity Calibration of Flush-mount Microphone Sets**



The GRAS OP0023 contains calibration adapters for 1/2", 1/4" and 1/8" sizes of GRAS Flush-mount Microphone Sets.

These adapters are designed exclusively for sensitivity calibration of the GRAS 47AX, 47AD, 47BX, and 47DX microphones using a GRAS pistonphone, such as the 42AP. They are not compatible with the GRAS 42AG sound calibrator.

## GRAS RA0216

**Field verification adapter for 67AX/AD**



This is a pistonphone adapter which is designed for field verification of the 1/2" flush-mount microphone included in GRAS 67AX/67AD Ground Array Microphone kits.

## GRAS RA4801

**Adapter for sensitivity calibration of 48LA/48LX-1**



The RA4801 is an adapter for sensitivity calibration of 48LA and 48LX-1 UTP microphones. It can be used with a pistonphone such as the GRAS 42AP or a sound calibrations, such as the GRAS 42AG.

## GRAS OP0025

**Kit with RA0202 Sensitivity Calibration adapter of 1/4" Surface Microphones**



The GRAS OP0025 kit contains a calibration adapter for GRAS 1/4" precision Surface Microphones.

The GRAS OP0025 kit includes the RA0202 sensitivity calibration adapter, designed specifically for GRAS 40LA and 40LS 1/4" surface microphones. This adapter is compatible exclusively with GRAS pistonphones, such as the 42AP.

## GRAS RA0236

**Adapter for frequency calibration of 46BC and 46BL-1**

Adapter for frequency calibration of GRAS 46BL-1 and 46BC microphone sets. It is intended for use with the RA0014 electrostatic actuator during frequency calibration procedures.

## GRAS RA4800

**Adapter for Sensitivity Verification of Flush/Surface Microphones**



RA4800 is a field verification adapter for UTP, surface-mount, and flush-mount microphones.

With this adapter, it is possible to perform quick and reliable in-situ sensitivity verification without having to dismount the microphone. The adapter fits sound calibrators and pistonphones fitted with 1" collar, such as GRAS 42AG and 42AP.

## GRAS RA0571

**Actuator Adapter for 40PO-L/H Microphones**

Adapter for frequency calibration of GRAS 40PO-L and 40PO-H microphone sets. It is intended for use with the RA0014 electrostatic actuator during frequency calibration procedures.

## GRAS GR0630

### Connecting Piece for Array Modules



Used to extend Array Module GRAS PR0002 in the horizontal direction.

## GRAS RA0107

### Spacer Set for Array Modules



A set of 6 (50mm) GR0707 spacers used to extend PR0002 array module in the vertical direction, together with corresponding top nut (SK4003) and bottom screw (SK1515).

## GRAS PR0002

### Module for Array Microphones, variable



PR0002 has 23 positions for microphones, spaced at 25 mm intervals. The microphones can also be spaced with intervals of 50 mm, 75 mm or 100 mm. CCP cable is used. The holder RA0185 is available for mounting array microphones with SMB connector, and a special holder RA0245 is available for mounting 1/4" microphone sets with Microdot connector. To be mounted on the AL0006 Tripod and the stainless-steel RA0094 Tripod Adapter (for 8 microphones). These are standard solutions, but GRAS also offers alternative sizes and shapes of array modules.



RA0185



RA0245

## GRAS GR0625

### End Piece Array Modules



For Array Module GRAS PR0002.

## GRAS GR0707

### Spacer for Array



The 50 mm spacer is used to extend PR0002 Array Module in the vertical direction.



CCP Cable Holders	
RA0185	Holder for cable with SMB connector
RA0245	Holder for cable with Microdot connector

## GRAS AK0040

### Standard 19" Rack Kit



AK0040 is a shelf for mounting instrument cabinets, e.g., GRAS Power Modules, and can itself be mounted in a standard 19" instrumentation rack via its flanges. It can house instruments 133 mm high and is wide enough to contain instruments up to a total width of 430 mm.

## GRAS AB0002

### Mains Adapter EU



Regulated 230 V AC  
- 15 V DC 7.5 W.  
Connector for European Union.

## GRAS AK0096

### Mounting Plate



For mounting two GRAS Power Modules (12AA/12AK) side-by-side.

## GRAS AB0003

### Mains Adapter USA



Regulated 110 V AC  
- 15 V DC 7.5 W.  
Connector for United States.

## GRAS AB0005

### Mains Adapter, EU/UK/USA



SMPS regulated 100–240 V AC – 6 V DC 10 W.  
Connector for European Union, United Kingdom, and United States.  
Specify connector when ordering.

## GRAS AB0006

### Mains Adapter UK



Regulated 230 V AC – 15 V DC 7.5 W  
Connector for United Kingdom.

## CCP Coaxial Cables, Microdot-BNC

For 1/4" and 1/8" Microphone Sets,  
max. temperature 70°C



- AA0070 3 m
- AA0071 5 m
- AA0072 10 m

## CCP Coaxial Cables, SMB Angled-BNC

For Array and QC Microphones



- AA0081 1 m
- AA0078 3 m
- AA0080 10 m

## CCP Coaxial Cables, Microdot-Microdot

CCP Coaxial Cables, Microdot-Microdot



- AA0064 3 m

## CCP Coaxial Cables, SMB-SMB

For Array and QC Microphones



- AA0043 3 m
- AA0044 10 m

## CCP Coaxial Cables, BNC-BNC

for 1/2" Microphone Sets



- AA0032 0.5 m
- AA0033 1 m
- AA0034 2 m
- AA0056 3 m Thin and flexible
- AA0035 3 m
- AA0036 5 m
- AA0037 10 m
- AA0060 15 m
- AA0038 30 m

## CCP Coaxial Cables, SMB-BNC

CCP Coaxial Cables, SMB-BNC for Array and QC microphones



- AA0025 1 m
- AA0027 3 m
- AA0026 5 m
- AA0028 10 m
- AA0055 20 m
- AA0029 30 m

## CCP High Temperature Cable, Microdot-Microdot CCP Coaxial Cable, max temperature 150°C



AA0064 3 m

## CCP High Temperature Cable, Microdot-BNC CCP Coaxial Cables, Microdot-BNC for 1/4" and 1/8" Microphone Sets, max temperature 150°C



AA0018 3 m

## CCP High Temperature, Microdot-SMB CCP Coaxial Cables, Microdot-SMB, max temperature 150°C



AA0049 10 m

## Watertight and Heat Resistant CCP Cables

- AA0107 1 m BNC – BNC
- AA0108 3 m BNC – BNC
- AA0121 5 m BNC – BNC w rubber sleeve
- AA0109 10 m BNC – BNC
- AA0110 30 m BNC – BNC

These cables are watertight and can be used at temperatures up to 125°C, for example with the 146AE 1/2" CCP Free-field Microphone Set.

AA0121 has a rubber sleeve at one end.

## Cable Replacement Kits for 147AX

- RA0393 5 m
- RA0394 10 m
- RA0395 20 m
- RA0396 Custom length

The repair kits comprise a key for screw-mounting one end of the cable to the 147AX' housing.

## LEMO Cables—Standard

Standard Cables 1B 7-pin LEMO to 1B 7-pin LEMO



- AA0008 3 m
- AA0009 10 m

## LEMO Cables—4-pin to 7-pin

Standard Cables 4-pin LEMO to 1B 7-pin LEMO



- AA0057 3 m

## LEMO Cables for Outdoor Microphones

LEMO Cables for Outdoor Microphones



- AA0003 3 m
- AA0002 10 m
- AA0015 100 m—on cable drum
- AA0016 200 m—on cable drum

## LEMO Cables—5-pin to 7-pin

Standard Cables 5-pin LEMO to 1B 7-pin LEMO



- AA0091 3 m

## LEMO Cables for Low-noise Systems

LEMO Cables for Low-noise Systems



- AA0046 3 m
- AA0047 10 m

## LEMO Cables for Intensity Probes

LEMO Cables for Intensity Probes



- AA0006 2 m—4-pin
- AA0021 5 m—12-pin

## Adapter Cables for 50AI and 60LK



- AC0002 Adapter Cable for GRAS 50AI-B for use with 01dB Symphonie
- AC0003 Adapter cable 12-pin LEMO to 2 x 7-pin LEMO for GRAS 50AI-C.
- AC0005 Adapter Cable for GRAS 50AI-D for Use with Müller BBM and OROS analyzers
- AC0008 Adapter Cable for GRAS 50AI-D for Use with 01dB Harmonie and Soundbook
- AC0010 Adapter Cable 18-pin LEMO to 2 x 7-pin LEMO

## GRAS AE0046

### BNC male–Microdot Female Adapter



Used for a cable terminated with a Microdot connector to connect to a BNC female (e.g., Power Module/Input Module)

## GRAS AE0101

### AE0101 Microdot – BNC Adapters



Microdot Male – BNC Male Adapter

## GRAS AE0074

### BNC Female-female Adapter



This adapter is used for interconnecting two cables which are terminated with BNC male connectors

## Windscreens



The GRAS windscreens are all size optimized and their special, open-cell foam structure is designed to resist a humid environment and not influence the sound pressure measurement result significantly.

Frequency-dependent attenuation is to be expected, if the windscreen gets wet. Therefore windscreens are not intended as rain protection.

Large pressure fluctuations caused by turbulence can be attenuated by up to 20 dB.

[Windscreens for outdoor microphones can be found on page 110.](#)

### Spherical Windscreens

- AM0363** For 1" microphone
- AM0069** For 1/2" microphone
- AM0071** For 1/4" microphone
- AM0364** For array microphones



### GRAS AI0001

#### Elliptical Windscreen for Intensity Probes



Provides good protection at wind speeds of more than 0.5 m/s and is able to reduce pressure fluctuations caused by turbulence by up to 20 dB.

### Windscreen for 147EB—High Temperature

- AM0387-1** Windscreen, 1 pc
- AM0387-4** Windscreens, 20 pcs.



High-temperature windscreen especially designed for 147EB. It has a plastic ring inside that locks it to 147EB.

### Windscreen for 147AX—High Temperature

- AM0388-1** Windscreen, 1 pc
- AM0388-2** Windscreens, 5 pcs.



High-temperature windscreen especially designed for 147AX.

### GRAS AM0376

#### Elliptical Windscreen for Rugged CCP Intensity Probes



Fits the rugged CCP Intensity Probe 50GI-P and 50GI-RP.

### Windscreen for 146AE—High Temperature

- AM0391-1** Windscreen, 1 pc
- AM0391-2** Windscreens, 20 pcs.



High-temperature windscreen especially designed for 146AE. It has a plastic ring inside that locks it to 146AE.

12AA	92	40EN	22	46AC	18	AA0008	121
12AD	91	40GI	24	46AD	15	AA0009	121
12AG	93	40GK	24	46AE	14	AA0015	121
12AK	92	40HF	52	46AF	18	AA0016	121
12AL	94	40HH	52	46AG	19	AA0018	120
12AN	95	40HL	53	46AM	15	AA0021	121
12AQ	94	40HT	52	46AN	37	AA0025	119
12AR	91	40LA	33	46AO	15	AA0026	119
12AU	96	40LS	33	46A0-S2	15	AA0027	119
12AX	95	40PH-10	38	46AP	19	AA0028	119
		40PL-10	38	46AQ	15	AA0029	119
12BA	97	40PL-11	38	46AR	18	AA0032	119
12BB	97	40PM	26	46AZ	37	AA0033	119
12BE	97	40PM-1	26	46BC	16	AA0034	119
12BC	97	40PO-L	26	46BD	16	AA0035	119
12BD	97	40PO-H	26	46BE	16	AA0036	119
12BF	97	40PP-10	27	46BF-1	18	AA0037	119
		40PP-10-S1	27	46BG	16	AA0038	119
12HF	98	40PS-1	33	46BH-1	19	AA0043	119
12HM	98	40SA	36	46BL-1	17	AA0044	119
		40SC	36	46BP-1	19	AA0046	121
14AA	64			46DD	17	AA0047	121
		41AC	49	46DE	17	AA0049	120
26AB	43	41AM	48	46DP-1	19	AA0055	119
26AC-1	43	41CN	48			AA0056	119
26AG	42			47AC	37	AA0057	121
26AI	42	42AC	62	47AD	34	AA0060	119
26AM	42	42AE	63	47AX	34	AA0064	119
26AN	43	42AG	63	47BG-FV	34	AA0064	120
26AS	43	42AP	62	47BX	34	AA0070	119
26CA	44			47HC	53	AA0071	119
26CB	45	43AA	70			AA0072	119
26CC	45	43AA-S2	70	48LA	32	AA0078	119
26CF	44	43AA-S3	70	48LX-1	32	AA0080	119
26CG	45	43AB	70			AA0081	119
26CI	44	43AC	71	50AI-B	56	AA0091	121
26CK	44	43AC-S1	71	50AI-C	56	AA0107	120
26CS	45	43AC-S4	71	50AI-D	56	AA0108	120
26CT	45	43AC-S5	71	50GI	57	AA0109	120
26HG	43	43AC-S6	71	50GI-P	58	AA0110	120
26TC	43	43AC-S7	71	50GI-R	57	AA0121	120
26TK	42	43AF	71	50GI-RP	58		
		43AG	72			AB0002	118
40AC	22	43AG-1	72	51AB	65	AB0003	118
40AD	21	43AG-2	72			AB0005	118
40AE	20	43AG-3	72	67AX	38	AB0006	118
40AF	22	43AG-4	72	67HA	39		
40AG	23	43AG-5	72	67HB	39	AC0001	109
40AI	24	43AG-6	72	67SB	83	AC0002	121
40AK	24	43AG-7	72	67TS	35	AC0003	121
40AM	20	43AG-8	72	67TS-1-CL	35	AC0005	121
40AN	22	43AG-9	72			AC0008	121
40AO	21	43BA	73	90AA	66	AC0010	121
40AP	23	43BA-1	73	90AB	66		
40AQ	20	43BA-2	73	90CA -S2	67	AE0001	110
40AR	22	43BA-3	73			AE0046	122
40AU-1	23	43BB	73	146AE	14	AE0074	122
40AZ	20					AEO101	122
40BD	21	44AA	86	147AX	14		
40BE	20	44AB	86	147EB	14	AF0008	100
40BF	22						
40BH	23	45BB	78	246AE	14	AG0001	102
40BI	24	45BC	79			AG0002	102
40BP	23	45CA	80	AA0002	121	AG0003	102
40DD	21	45CB	82	AA0003	121		
40DP	23	45CC	84	AA0006	121	AI0001	123

AK0040	118	KB0061	114	RA0042	115	RA0251	113
AK0096	118	KB0065	114	RA0045	76	RA0252	74
		KB0066	114	RA0045-S1	76	RA0262	104
AL0003	106	KB0068	114	RA0045-S4	76	RA0302	106
AL0004	105	KB0069	114	RA0045-S5	76	RA0312	104
AL0005	105	KB0070	114	RA0045-S6	76	RA0336	104
AL0006	105	KB0071	114	RA0048*	115	RA0340	103
AL0007	106	KB0072	114	RA0049	115	RA0341	115
AL0008	105	KB0073	114	RA0052	112	RA0355	103
AL0010	64	KB0077	114	RA0056	75	RA0357	108
AL0011	64	KB0078	114	RA0057	75	RA0360	103
AL0012	105	KB0090	114	RA0058	112	RA0390	103
AL0013	105	KB0091	114	RA0062	102	RA0391	115
AL0017	64	KB0110	113	RA0062-S1	102	RA0392-1	106
AL0021	64	KB0111	113	RA0063	100	RA0392-10	106
AL0028	105	KB1060	114	RA0067	108	RA0393	120
AL0029	105	KB1061	114	RA0069	115	RA0394	120
AL0030	88	KB1065	114	RA0070	112	RA0395	120
AL0030-1:	89	KB1066	114	RA0073	100	RA0396	120
AL0030-2:	89	KB1068	114	RA0075	74	RA0401	76
AL0030-3:	89	KB1069	114	RA0076	112	RA0402	76
AL0035	105	KB1070	114	RA0077	108	RA0403	77
		KB1071	114	RA0087	109	RA0404	77
AM0009	110	KB1090	114	RA0080	102	RA0424	104
AM0029	109	KB1091	114	RA0081	101	RA0425	104
AM0033	109	KB3000	114	RA0082	100	RA0427	104
AM0037	109	KB3001	114	RA0083	102	RA0428	104
AM0038	109	KB3002	114	RA0086	108	RA0501	107
AM0052	110	KB5000	114	RA0088	111	RA0502	107
AM0069	123	KB5001	114	RA0090*	115	RA0504	106
AM0071	123	KB5002	114	RA0091	103	RA0530	107
AM0089	110	KB5010	114	RA0092	104	RA0531	107
AM0363	123	KB5011	114	RA0093	105	RA0533	107
AM0364	123			RA0094	105	RA0567	103
AM0376	123	OP0023	116	RA0096	105	RA0571	116
AM0387-1	123	OP0025	116	RA0096-S1	105	RA4800	116
AM0387-4	123			RA0107	117	RA4801	116
AM0388-1	123	OR5003	112	RA0113	74	RA0524	103
AM0388-2	123	OR5389	112	RA0114	112	RA0526	103
AM0391-1	123			RA0115	112	RA0527	103
AM0391-2	123	PR0002	117	RA0116	113	RA0566	111
		PR0003	87	RA0117	108	RA4802	65
DB0475	107	PR0004	87	RA0119	115	RA4805	65
DB0507	107			RA0122	108	RA4810	107
DB0521	107	RA0001	101	RA0125	102	RA4810-2	107
		RA0002	101	RA0127	104	RA4810-10	107
GR0010	100	RA0003	100	RA0131	104	RA4811	107
GR0315	111	RA0006	101	RA0132	101	RA4811-2	107
GR0316	112	RA0007	101	RA0161	101		
GR0317	111	RA0009	110	RA0172	113	SK0017	106
GR0318	111	RA0014	65	RA0173	101	SK0057	106
GR0319	111	RA0014-S1	65	RA0177	103		
GR0320	111	RA0015	65	RA0190	101		
GR0321	111	RA0016	108	RA0200	101		
GR0435	111	RA0017	100	RA0210	101		
GR0436	111	RA0017	112	RA0216	116		
GR0437	111	RA0018	108	RA0236	116		
GR0438	111	RA0019	100	RA0237	113		
GR0440	111	RA0020	101	RA0238	113		
GR0625	117	RA0020-A	101	RA0238	113		
GR0630	117	RA0022	101	RA0240	113		
GR0707	117	RA0023*	115	RA0240	113		
GR0723	112	RA0024*	115	RA0241	113		
GR1176	111	RA0038	74	RA0241	113		
		RA0039	74	RA0249	113		
KB0060	114	RA0041	110	RA0250	113		



*An Axiometrix Solutions Brand*

**GRAS Sound & Vibration**

Skovlytoften 33 · DK-2840 Holte

Phone +45 4566 4046

**[www.grasacoustics.com](http://www.grasacoustics.com)**